



MARINE SURVIVAL
INNOVATIVE QUALITY

Contents

Medical	8
Survival	14
Rations	20
Protection	22
Location	26
Search	30
Security	37

Meet the team



Stefanie Frieze-Davies
BCB Marine Manager
t: +44 786 631 3278
e: sk@bcbin.com



Stuart Morris
Marine Business
Development manager
t: +44 29 2043 3700
e: sm@bcbin.com



Phil Jones
Marine Contractor
t: +44 798 960 4136
e: pjones@bcbin.com



Andrew Howell
Managing Director
e: arh@bcbin.com



Kate Graham
Admin Assistant
e: kg@bcbin.com

www.bcbin.com

BCB International Ltd, Clydesmuir Road,
Cardiff, UK, CF24 2QS UK

Tel: +44(0)2920 433 700

Fax: +44(0)2920 433 701

email: info@bcbin.com

Marine Pedigree

BCB has been a prime contractor to the life raft and lifeboat industry for over 60 years.

Originally founded in 1854. BCB are a manufacturer and designer of survival equipment; primarily for the marine and military markets. Over 50% of BCB's production is exported.

Continuous and Never Ending Innovation

BCB's Continuous and Never Ending Innovation policy, (CANEI for short).

We welcome your requests for new product ideas and improvements to any existing life saving equipment.

Dependent upon feasibility, BCB will consider the possibility of designing and developing **free of charge** new products, contact us for more information.

Manufacturer

In addition to safety and survival equipment we also design and manufacture a wide range of equipment including:

- Innovative clothing
- Creams powders and liquid formulations
- Eco friendly fuels

Competitive price promise

As a manufacturer, we are sure you will find our prices are **highly competitive**.

If however you find a better price elsewhere in the marketplace, for a comparable product let us know, **and we will try to better it**.



BCB International Ltd. endorses and actively supports the advancement of responsible corporate citizenship and universal social and environmental principles to meet the challenges of globalization. To this end we uphold the United Nations global compact and the 10 principles of core values. In the areas of human rights, labour standards, the environment and anti-corruption to aid and embrace corporate citizenship in the world economy.

Scan the QR codes to find us on social media



ISO Certified

BCB International Ltd and BCB Marine Ltd are approved to ISO 9001:2008 International Quality Standards.

The majority of our products are SOLAS approved.



Product certification



BRITISH QUALITY

All of our products are manufactured in accordance with ISO 9001;2008 and many items are NATO approved.

- Numerous SOLAS approvals
- ISO 9001;2008 CERTIFIED
- OVER 200 N.A.T.O APPROVALS
- AWARDED TWO QUEENS AWARDS FOR EXPORT ACHIEVEMENTS
- AWARDED THREE SOLDIER TECHNOLOGY
- UN REGISTERED FOR OVER 30 YEARS



Three Soldier Technology awards for innovation



Two Queen's Awards for Export Achievement

CONTINUOUS INNOVATION

BCB's Continuous and Never Ending Innovation Policy (CANEI) has resulted in hundreds of quality innovative products, many of which were and continue to be developed in partnership with those who travel to the extremes.

- OVER £1 MILLION INVESTED INTO R&D IN THE LAST FEW YEARS
- DIVERSE EXPERTISE
- RAPID PROTOTYPING
- CONTINUOUS AND NEVER ENDING INNOVATION
- MILITARY FOCUS USER GROUP
- COLLABORATIVE UNIVERSITY AND BUSINESS PARTNERSHIPS

A BRIEF HISTORY OF BCB

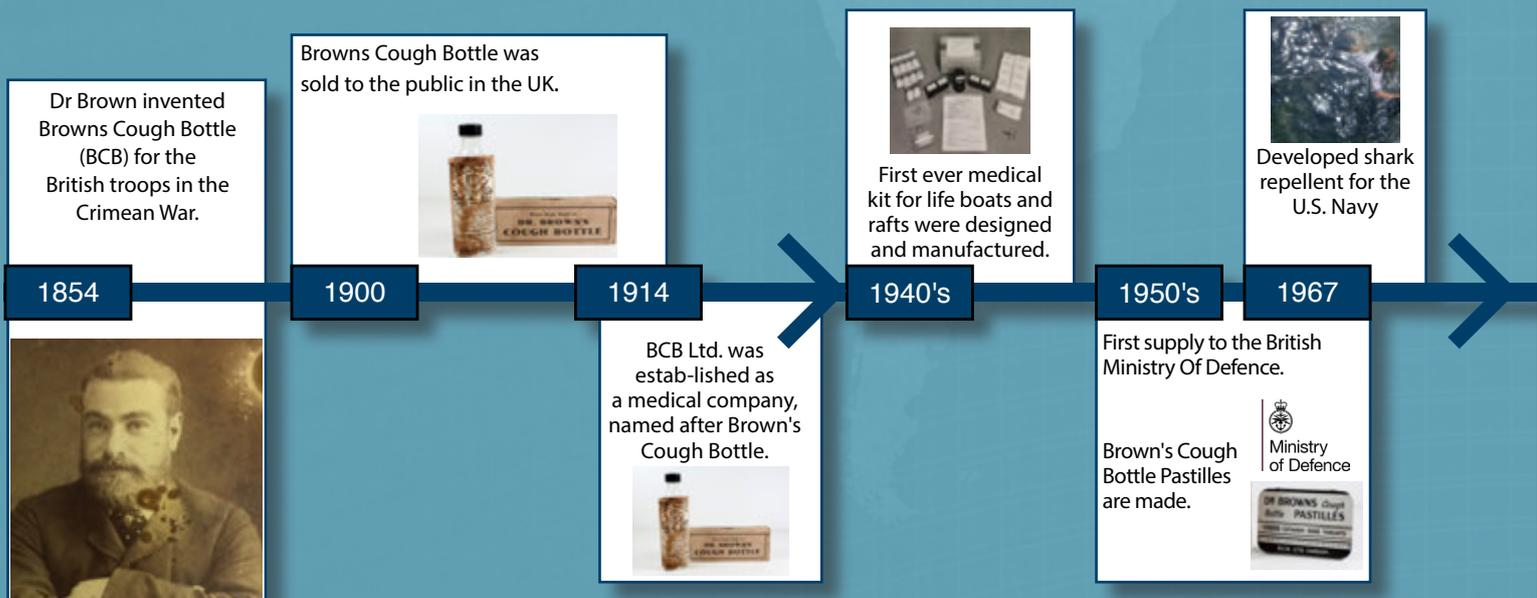

Approvals:



PRIME MANUFACTURER

BCB are a Prime Manufacturer with two factories in South Wales.

CHEMICAL MANUFACTURING



TEXTILES AND WEBBING



CLOTHING MANUFACTURING



KIT AND PACK ASSEMBLY



BCB HQ and production, Cardiff, UK



BCB FireDragon production, Llanelli, UK



1975 - Supply of all medical equipment to the first successful expedition to the South West face of Everest

1970's

1979 - BCB International Ltd was established to develop the military range and export.



First supply to the United Nations

1980's

1988 - Winner of first Queen Award for Export Achievement.

1985 - Pioneer brand of outdoor accessories developed.



1999 - Robotic design begins
1993 - LRQA ISO Quality Control approval



1990's

2007 - BCB International Inc. was established in the USA



2000's

2009 - Blast Boxers were designed.



2014 - BCB Adventure was set up for the outdoor market



2010's

2013 - FireDragon eco-friendly cooking fuel was launched.



Research & collaboration with:



FIRST AID KIT
TYPE C



PAGE 8

FIRST AID KIT
SOLAS



PAGE 8

FISHING KIT



PAGE 17

HELIOGRAPH



PAGE 30

FLOATING
KNIFE



PAGE 18

MATCHES



PAGE 16

QUOIT + LINE



PAGE 31

SEARCHLIGHT



PAGE 27

TPA



PAGE 22

LIFERAFT SURVIVAL
MANUAL

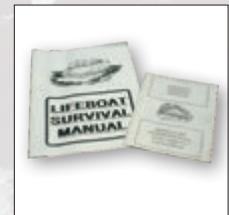

PAGE 17

YOU COVERED.

AXE

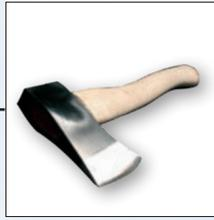

PAGE 18

BAILER



PAGE 16

HYPOTHERMIA BLANKET



PAGE 22

KNIFE (JACK)



PAGE 18

PLASTIC BUCKET



PAGE 17

SEA ANCHOR



PAGE 16

SEA SICK TABLETS



PAGE 12

LIGHTSTICK

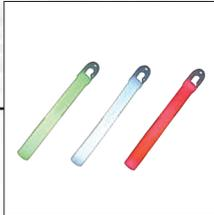

PAGE 31

WATER DIPPER



PAGE 17

SOLAS NO.2



PAGE 17

Category "C" First Aid Kit



- UK MCA/Lloyds Register of Shipping Type Approved for Category "C" Vessels. The kits are mandatory for life boats and rafts.
- Maximum certificated drop height 36 metres.
- Multilingual
- This kit complies fully with EC Directive 92/29, MSN 1768 and is CE marked.
- Comes in a heavy duty waterproof resealable pouch.
- Available in two versions MM004 and MM009
- **Dimensions:** 36 x 30 x 6cm (14.1 x 11.8 x 2.3")
- **Weight:** 835g (29.4 oz)

Contents: Burn bag & gloves, survival instructions, paratulle, bandages, antiseptic cream, pocket face mask, triangular bandages, plasters, pocket gauze, antiseptic wipes, 5" scissors, safety pins, anti-seasickness tablets, zinc oxide tape, glycerine trinitrate, loperamide, paracetamol, ibuprofen, elastic adhesive tape.

CODE: MM004 Foil packed for lifeboats/liferafts

CODE: MM009 Contained in a first aid kit box with a St. Johns First Aid Manual



"SOLAS" Liferaft/Lifeboat First Aid Kit



The predecessor of the Category "C" kit, this kit is Lloyds Register of Shipping Approved for use in lifeboats and liferafts on ships registered outside the EC. Comes in a heavy duty waterproof re-sealable pouch.

- Maximum drop height 36metres.
- Multilingual
- **Dimensions:** 36 x 30 x 6cm (14.1 x 11.8 x 2.3")
- **Weight:** 500g (17.6 oz)

Contents: Burn bags, paratulle, survival instructions, bandages, 5"scissors, antiseptic wipes, safety pins, plasters, triangular bandages, paracetamol, compressed bandages, elastic adhesive bandages, sterile gauze swabs.

CODE: MM001





Oceanic First Aid Kit

Designed for use in the survival packs of leisure liferafts.

- **Dimensions:** 34 x 27.5 cm (13 x 11")
- **Weight:** 415g (14.6 oz)

Contents: Antiseptic cream, paracetamol, WOW bandages, plasters, bandages, 5" scissors, plaster roll, triangular bandages, paratulle, safety pins, survival instructions.

CODE: MM005



Ships Additional First Aid Kit

Designed for use on the bridge, galley, engine room etc and supplied complete with a carrying case.

- **Dimensions:** 34 x 25 x 10cm (13.3 x 9.8 x 3.9")
- **Weight:** 1kg (35.2 oz)

Contents: Triangular bandages, bandages, safety pins, plasters, dressings, sterile gauze swabs, disposable gloves, saline eyewash, sterile cotton wool, hard box container.

CODE: MM012

US Coast Guard - Approved First Aid Kits



LIFERAFT

US Coast Guard approved first aid kit is certified to meet the requirements you need for life raft usage. Contents are sealed in a waterproof soft pouch

Case contains:

CODE: MM501

- 16 - Adhesive Strips
- 1 - Bandage Compress 10cm (4")
- 4 - Bandage Compresses 5cm (2")
- 1 - Gauze Compress
- 1 - Triangular Bandages
- 4 - Eye Pads and Strips
- 1 - 1 oz. Eye wash
- 10 - Ammonia Inhalants
- 10 - BZK Antiseptic Wipes
- 6 - Burn Gel Packets
- 1 - Tourniquet
- 50 - Aspirin Tablets
- 1 - Wire Splint
- 1 - Gauze Bandages 10x15cm (4x 6")

LIFEBOAT

US Coast Guard approved first aid kit certified to meet the requirements you need for life boat usage. Contents are sealed in a waterproof, high impact plastic case.

- 1 Box of 10 - Ammonia-Inhalants
- 16 - Adhesive Strips
- 1 - Bandage Compress 10cm (4")
- 2 - Bandage Compress 5cm (2")
- 1 - Gauze Compress, 60x5cm (24x2")
- 1 - Triangular Bandages, 10cm (4")
- 1 - Gauze Bandages, 10cm (4")
- 1 - Eye Flush, 28g (1oz)
- 4 Sets - Eye Pads & Strips
- 6 - Burn Cream Packets
- 1 Box of 10 - BZK-Towelettes
- 1 - Tourniquet
- 50pc - Aspirin-Tablets
- 1 - Wire Splint

Size: 23x23 cm (9" x9")

CODE: MM502

Medical - First Aid Kits

ISAF First Aid Kit

Includes:

- Sunscreen.
- Sunburn cream.
- Drinking water (1/2 Litre).
- Complies with International Sailing Federation for racing under special regulations categories 1 & 2.
- Dimensions: 34 x 25 x 6cm (14.1 x 9.8 x 2.3")
- Weight: 510g (17.9oz)

Contents: Antiseptic cream, conforming bandages, plasters, dressings, bandages, adhesive strapping, triangular bandages, paratulle, safety pins, survival instructions, sunblock, aftersun, drinking water



CODE: MM010

Designed for compliance with the ISAF (International Sailing Federation) and RORC guidelines for racing under Special Offshore Regulations Categories 1 & 2. These first aid kits also include emergency high factor sun-screen, emergency sunburn treatment cream and a half-litre drinking water ration.

Supplied in a waterproof resealable foil bag, these ISAF First Aid Kits are ideal for adding to your Liferaft Grab-Bag.



YC4 Full Pack

- 5inch Scissors
- Waterproof Sterile Plasters (20'S)
- Dressings - no 8
- Dressing - no 9
- Sterile gauze Swab (PACK of 5)
- Triangular Bandage
- Cetrimide Cream 0.5W/W 15g
- Avomine Tablets (Pot of 60)
- Paracetamol
- Conforming Bandage

Weight: 260g (9 oz)

Size: 15x23 cm (6x9")

CODE: MM023



YC4 Part Two Kit

- 5inch Scissors
- Waterproof Sterile Plasters (20'S)
- Dressings - no 8
- Dressing - no 9
- Sterile gauze Swab (PACK of 5)
- Triangular Bandage

Weight: 144g (5 oz)

Size: 15x23 cm (6x9")

CODE: MM024

LIGHTWEIGHT FIRST AID KIT

IDEAL FOR A PLEASURE LIFERAFT

A versatile and lightweight first aid kit. The ultralight dry bag keeps the weight down and helps keep your first aid kit safe and dry. A durable buckle secures the roll-top closure and acts as a grab handle.

- accident evaluation report
- large disposable gloves
- folding scissor
- waterproof sterile plasters
- anchor dressing
- antiseptic wipes
- safety pins
- conforming bandage
- paracetamol
- triangular bandage (non woven)
- dressings
- wound closure strip
- hospiform bandage
- first aid hints
- ultralight dry bag (red, 1 litre)

Weight: 108g (3.8oz)

CODE: CK702



Trauma Pack

First Responder Emergency pack

A one-time use Trauma Pack

The Pack has been trialled by emergency staff in Namibia and is a low-cost kit that can be used by anyone. The pack comes with simple, but life-saving instructions which are colour and number coded for easy use.



1. Bandages – several bandages and gauze for bleeds, gloves, and a tourniquet



2. Airway – 2 sizes, with tongue depressors



3. Neck – Tear and Wear neck collar, adjustable in size



4. Chest – Plastic chest seal, tape, and scissors



5. Burns – Cling film



6. Pelvis – Pelvic sling with buckle



7. Limbs – Foldable arm and leg splint with Velcro ties



8. Transport – Lightweight stretcher with handles



9. Warm – Lightweight hypothermia prevention blanket



'Seasickness will interfere with your survival chances as vomiting removes precious body fluid, and seasickness in general makes you more prone to hypothermia and impairs your will to survive'



Anti-sea sickness tablets

- Supplied in tubs of 60 tablets
- Dimensions: 5.4 x 3.5 cm (2.1 x 1.4")
- Weight: 22g (0.7oz)

CODE: MM029



Scissors

- 5" scissors blunt/blunt.

CODE: RM056



Head Immobiliser

- ABS impact resistant plastic construction
- New improved hand holes designed to accommodate gloved hands
- Moulded speed clip pins
- X-Ray translucent
- MRI compatible
- Floats for water rescue
- Lifts up to 1000lbs



Anaconda Splint

Lightweight malleable and waterproof splint, versatile and flexible, used to immobilise and support broken or sprained limbs.

Can be cut to required size and used for finger splints

Rolled Size: 11cm x 8cm (4.5" x 3")

Length: 91cm (36")

Weight: 140g (4.9 oz)

CODE: RY273

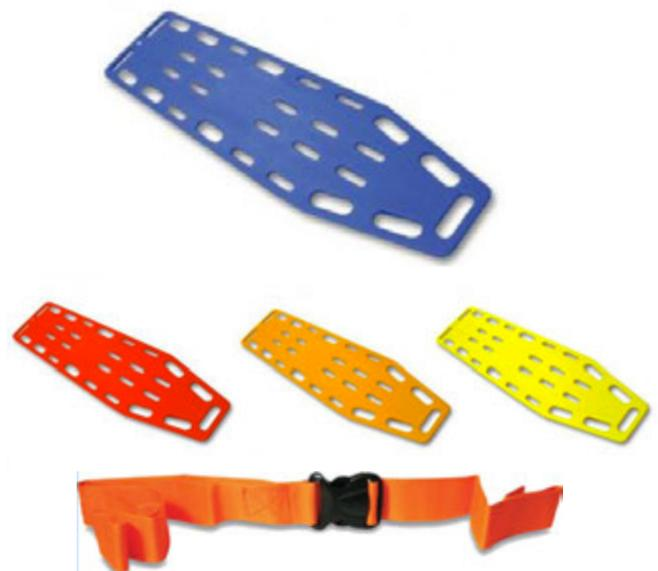

Spine Board and Straps

Unique head chin strap is designed to conform to patient. Head Immobilizer is simple to use, Lightweight and easy to use. Composed of a universal attachment base and two durable head straps, closed-cell foam head blocks, with one set of head and chin straps

The head immobilizer can be used on all standards backboards.

Scoop Stretcher

This two piece aluminium orthopedic stretcher can be positioned under the patient without moving them and once locked in place immobilises the patient for transport.

Features:

- Effective hooking and unhooking device for the stretcher uncoupling
- Adjustable length with automatic locking device
- Bag with 3 quick unhooking safety belts for the immobilization of the patient
- Once folded easy arrangement inside the ambulance
- Completely built with light and sturdy aluminium
- Large handhold for gloved hands

Device certified according to the European harmonized safety standards, in conformity with standard EN 1865:2001

CODE: MF432



The Neil Robertson Stretcher

Neil Robertson's Naval service started in 1899 taking him across the world from the Outer Hebrides to Africa, and during World War 1 he was serving on HMS Blake. John Neil Robertson died at the age of 41 on 22 December 1914 and was buried, with full Naval honours, in Plymouth, England.

The first Neil Robertson stretcher was made at some point between 1906 and 1912. However, it is not known to what extent he contributed to its design. It is almost certain that he was part of a long list of contributors including Captain Fitzherbert, Captain C.A.W. Hamilton and Fleet Surgeon I.M. McElwee.

Manufactured from high quality duck canvas and ramin slats, the Neil Robertson stretcher has been widely used for 100 years.

The slats are stitched into the canvas to ensure both rigidity and casualty security. Ideal for casualty evacuation from confined spaces, or where vertical lifts only can be executed.

Dimensions: 150 x 38 x 18cm (Folded) (59 x 15 x 7")

Weight: 8 kg. (17.6lbs)

CODE: MF440 Standard Neil Robertson

CODE: MF441 Two Metre Version

CODE: MF442 NATO Version

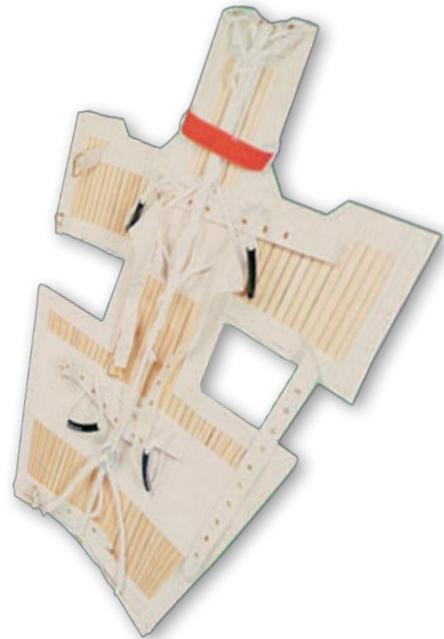

Orange Basket Stretcher

A rigid basket stretcher with multiple hand holes, lifting points & foot plate. Designed for hand, rope and helicopter rescue.

Features:

- Suitable for a wide range of situations.
- Strong polyethylene and aluminium structure
- Adjustable lifting bridles available
- Comes complete with patient restraint straps
- Moulded runners and handholds
- Resists chemicals and extreme temperature

Dimensions: 217 x 62 x 18.5 cm (85.4 x 24.4 x 7.2")

Weight: 13.5 kg (29.7lbs). Capacity: 278 kg (612.8lbs)

CODE: MF400



Waterproof Rescue Bag

Can be worn on the back with two padded shoulder straps. Made in a highly visible orange PVC, Two compression straps, external clear I.D window and waterproof zips.

- Strong hand carrying strap
- Fully watertight zip
- Highly visible ORANGE

Uncompressed size: 30 x 50 x 32cm (12 x 16 x 13")
CODE: CA969



Heavy Duty Cordura Expedition Bag

This bag is made of a Cordura material it has four strap handles on the top to make a four/two man carrying system to allow easy movability. A drag strap has been added if the user wishes to drag the bag across any environment – reinforced plastic feet ensure the bag is protected from the terrain.

- Easy to carry
- Detachable straps if the user needs to drag across ice
- Bag dimensions:
- High visibility
- Cordura Materials to be used on the ice
- Four/Two handled pulling system

Uncompressed size: 105 x 58 x 45 cm (42 x 23 x 18")

CODE: CA970

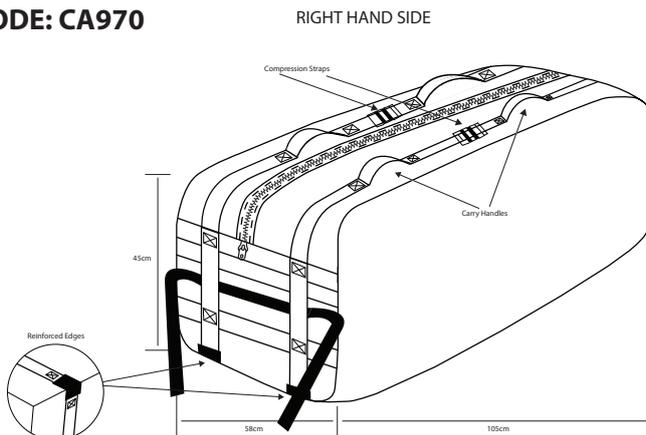



SURVIVAL ESSENTIALS KIT

A versatile and lightweight survival kit. The ultralight dry bag keeps the weight down and helps keep your kit safe and dry. A durable buckle secures the roll-top closure and acts as a grab handle.

Contents:

- Round boot laces • LED micro torch • Hypothermia space blanket • Hunters micro tool • Fireball flint and striker (Grand) • White nylon cord • Night light • Sewing kits • Fishing kit • Wire saw • Waterproof matches c/w striker • Duck tape • Distress whistle • BCB survival instructions • Cotton wool balls • 2" Mayday signal mirror • Ultralight dry bag (Lime green, 1 litre)

Weight: 360g (12.6oz)

CODE: CK701



TREKKING ESSENTIALS KIT

A versatile and lightweight trekking kit. The ultralight dry bag keeps the weight down and helps keep your kit safe and dry. A durable buckle secures the roll-top closure and acts as a grab handle.

Contents:

- Round boot laces • Led micro torch • Emergency poncho • Petroleum jelly • Night light • Sewing kits • Mini folding knife • waterproof matches c/w striker • duck tape • Black cable tie • Distress whistle • Waterproof sterile plasters • Wound dressing • Dinc oxide tape • Ultralight dry bag (blue, 1 litre) paracord

Weight: 253g (8.9oz)

CODE: CK700



WATERPROOF SURVIVAL KIT

A waterproof roll-sealable pouch containing a survival kit.

- Lightweight
- Watertight seal
- Belt attachment
- Drawstring cord to loop over your neck

Contents:

- Matches mini folding knife • Button compass • Water purification tablets x 10 • Dry bag • Micro torch • Signalling mirror • Duck tape • Accident evaluation form • Razor blades • Nylon cord • Night light • Pencil sewing kit • Gold wire (12ft) • Fishing kit • Wire saw • Distress whistle • Fireball flint & striker • Survival instructions • Safety pins x 6

Size: 12 x 19.5cm (4.7 x 7.6")

Weight: 198g (6.9oz)

CODE: CK050



Lifeboat Matches

Stronger and more effective than standard matches, lifeboat matches have extra long heads and will continue to burn through strong winds and rain.

- NATO approved
- Hand-dipped and varnished
- 1 waterproof container including 25 matches.

CODE: CN327A
NATO approved



Plastic Bailer

Easy to grip handle, buoyant. Pliable and strong enough to withstand the 36 metre drop test. Lanyard hole.

Size: 18.5 x 12 x 13.5 cm (7.2 x 4.7 x 5.3")

Weight: 106 g (3.7 oz)

Capacity: 1065 ml

CODE: MF207A

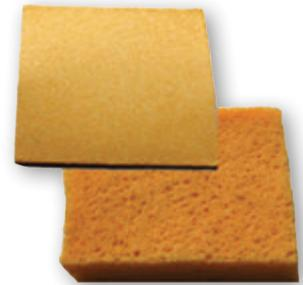

Compressed Sponge

Approximate dry/compressed size 8.3 x 8.3 x 1.6cm, (3.3 x 3.3 x 0.2") increasing to 10 x 10 x 1.5x cm (3.9 x 3.9 0.6") when wet.

Absorbency capacity approximately 170ml

CODE: MF300R



Liferaft Repair Kit

Small to large diameter rubber bungs designed to provide emergency repairs to a damaged life raft at sea.

CODE: MF022



Sea Anchor

Sea anchor designed for a liferaft, comes complete with 30 metres of line. Which hold up to 25 persons. The cloth of the Sea Anchor is 100% ripstop nylon and the tow-line is Polypropylene.

- **Folded length:** 38x12x6cm (15x4.7x2.4")
- **Rope length:** 16.4m (646")
- **Weight:** 300 grams (1.6 oz)

CODE: MF057



Liferaft Fishing Kit

Small, lightweight and compact. Instructions included.

Approx Contents:

- Line 36 Metres
- Winder
- Swivels (4)
- Hooks (4)
- Weights (10)

CODE: MM213



Drinking Vessels

- Available in either 250ml, 60ml or 50ml capacities.
- Graduated to measure exact amounts of water.
- Soft strong material withstands drop test.

Capacity	Weight	Code
50ml	5g (0.18oz)	MF121
60ml	8g (0.28oz)	MF121A
250ml	20g (0.7oz)	MF120

Lifeboat Water Dipper

- Made from rustproof metal and fitted with a 50 cm chain for dipping into a water tank or container.
- Designed to minimise spillage of lifeboat water.
- Weight: 320g (11.2 oz)

CODE: MF109



Lifeboat/Liferaft Manuals

- Printed on waterproof paper.
- Both manuals contain detailed survival instructions.
- Compliant with SOLAS Chapter III, Regulations 38.5.22/41.8.4 and IMO resolution A6.57(16) Annex 2
- Available in English.
- Also available in dual versions
 - German/English
 - Greek/English
 - Spanish/English

CODE: MF201 Lifeboat version

CODE: MF200 Liferaft version



SOLAS II Rescue Signal Table

Ideal for use in either life rafts or lifeboats. Information printed on both sides of the laminated card.

Fully approved.

Size: 18cm x 21cm (8.2" x 7.1")

CODE: MF501



Plastic Bucket

A 10 litre (17.5 pints) plastic bucket with rope lanyard pre-spliced onto the handle.

CODE: MF310



Liferaft Knife

Made from stainless steel and fitted with a lanyard ring and built in can opener. Safe for use in a liferaft. Can be opened with one hand.

CODE: MF304



Jack Knife

Fitted with single blade, Marlin'spike, screwdriver, can opener and steel loop for lanyard.

CODE: MF303

Floating knife

Tempered steel blade and wooden handle to assure buoyancy. Rounded blade makes this safe for use in liferafts.

- SOLAS APPROVED
- **Dimensions:** 13 x 2.5 x 1.5cm (5.1 x 1 x 0.6)
- **Weight:** 25g (0.8 oz)

CODE: MF302



Lifeboat Axe

- Hardwood handle,
- **Weight:** 0.97Kg (2.1 lbs)
- **Length:** 39cm (15.5 oz)

CODE: MF202A



Can Opener

This can opener folds flat, and is ideal for use on a life raft or lifeboat

- **Weight:** 10g (0.35")

CODE: MF122



HUNTSMAN MICRO TOOL

A very small version of the Hunter's Tool. Excellent for survival kits and as a pocket companion. Easy to fold open.

- Needle-nose pliers • Wire cutters • Can opener • Bottle opener
- Knife • Crimper • Small screwdriver • 2 large screwdrivers • Crosshead screwdriver • Files • Serrated saw/knife

Overall Length: 11cm (4"),
Closed Length: 7cm (2.8")
Weight: 106g (3.7oz)

CODE: CM056



HUNTSMAN TOOL

This super tool is of a strong, robust, stainless steel construction. Folding tools lock into position. The webbing pouch contains 12 screwdriver and Allen bits.

- Needle-nose pliers • Wire cutters
- Scissors • Knife blade • Marlin spike
- Wood/bone saw • Can/bottle opener
- Ruler • Lanyard attachment

Length: Folds to 11cm (4")
Weight: 310g (11oz)

CODE: CM057

FLASH TOOL

Strong, easy and quick to open multi-tool, with its small LED flash light (focused on the pliers head) it is ideal for those night time emergencies and a comfortable contoured handle.

- Needle nose pliers (sprung loaded) • wire cutters • LED Torch • Can opener • Philips screwdriver • Bottle Opener • Large Flat Screwdriver
- Serrated Knife Blade • Sharp double toothed saw • Smooth Edge blade
- Fishing Hook Remover • Serrated Knife Blade • Medium Flat Screwdriver
- Small Flat Screwdriver

2 Batteries included - CR1220
 Supplied in a durable nylon belt pouch

Overall Length: 17.7cm (10.9")
Closed Length: 10cm (3.9")
Weight: 270g (11oz)

CODE: CM648



MILLENNIUM ENERGY BAR

Available in 2 natural flavours. Cherry or raspberry. Each packet contains a fortified long life food bar.

- Vacuum packed
- 3 Year shelf life
- Energy: 409 Kcal
- More flavours are available subject to 1800 minimum order quantity.

Size: 16 x 6 x 1.5cm (6.3 x 2.4 x 0.6")

Weight: 84g (3oz)

CODE: RF0014R (RASPBERRY)

CODE: RF0014 (CHERRY)



Barley Sugar Rations

- Long shelf life as they are double hard boiled.
- Sealed in a waterproof tin.
- The tin can be used as an emergency cooking pan.
- **Weight:** 170g (6oz) per pack.

Size of tin: 11 x 8.2 x 2.8cm (4.3 x 3.2 x 1.1")

NATO approved: NSN-8970-99-700-2104

CODE: MM108 per pack

Food Rations

- Worldwide approvals held.
- 500g (17.6 oz) each.
- Available in cases of 24 or 30 rations.

CODE: MF104 (Case of 24)

CODE: MF106 (Case of 30)





Datrex emergency rations, the gold standard of food and water rations, are individual servings of filtered fresh water, bagged in a specially designed polymer-foil sachet. To consume tear open at the mark and sip straight from the bag. The high level filtering and outer protection is certified to keep the contents fresh for a minimum of five years in even the harshest environments.

- Purified water for immediate use
- Superior packaging materials for optimum durability
- USCG, Canadian Coast Guard, EC and NZ approval.
- 5 years shelf life.



Code: MF107A 125ml sachets

Code: MF107 Box

NSN: 8960 0112 4454 3



Water Purifying Tablets

Substantially reduces contamination in filtered water. These chlorine-based tablets neutralise bacteria and help protect you against water-transmitted diseases.

- 1 tablet treats 1 litre
- 2 x 50 tablets (foil wrapped)
- NATO approved
- **Weight:** 40g (1.4oz)

CODE: CR210

SEA WATER DESALINIZATION KIT MK 2, TYPE II

The desalination kit is a handheld, portable kit that can treat sea water, transforming it into drinkable water.

The kit contains a plastic bag that the user will fill with sea water.

When one of the kit's eight chemical bars is added to the bag, the process of desalting the water begins.

It takes about 60 minutes to make 473ml (one pint) of drinkable water. The plastic bag has a filter that will allow only fresh water to pass, and a valve that can be opened and close for easy use.

There is also mending tape in the kit in case the bag tears. The kit container is made out of heavy, moulded plastic. In the event the bag is unusable, the kit container may be used to desalt the sea water, as well.

The volume of treated water per hour is 450ml. One pack can produce over 8 x 473ml of water or 3.8 litres.

NSN: 4610-00-372-0592

Size: 11 x 11 x 6cm (4.3 x 4.3 x 2.3")

Mass: 750 grams

Life: 5 years from DoM

Certificate/Qualification: Complies to MIL-D-5531E

CODE: SF297



JERRY CAN COLLAPSIBLE

A handy camping companion, this water carrier folds up small enough to fit into a glove box and expands to hold 10 litres (21 pints).

- Robust
- Carrying handle
- Integral tap

Size (compressed): 20 x 25 x 6cm (7.8 x 9.8 x 2.4")

Size (expanded): 30 x 20 x 25cm (11.8 x 7.8 x 9.8")

CODE: CT026



HAND WARMERS (X 2)

Opening the sealed packaging lets oxygen react with the bag. Within a minute they release constant heat. Typically these packs are used for comfort, increasingly however, they are used in rescue operations where a survivor is trapped in a cold or exposed place.

- Hand warmers (40 pairs per box)

Working temp: 57°C to 70°C
Duration of max. heat: 7 hours

CODE: CL281 (40 PAIRS)

CODE: CL281A (LOOSE)



Foil Hypothermia Blanket

The lightest and most compact blanket in our range. Truly pocket sized it assists in the retention of up to 90% radiant body heat. Available in plain silver or with an olive outer

- Lightweight foil sheet
- **Dimensions:** 215cm x 150cm (85"x 59")
- **Weight:** 60g (2oz)

CODE: RP041 (plain silver)

NSN: 7210-99-991-0460

CODE: CL039 (olive/silver)



BODY WARMERS

Opening the sealed packaging lets oxygen react with the bag. Within a minute they release constant heat. Typically these packs are used for comfort, increasingly however, they are used in rescue operations where a survivor is trapped in a cold or exposed place.

- Body warmers (40 per box)

Working temp: 50°C to 65°C
Duration of max. heat: 20 hours

CODE: CL280 (40 PACKS)

CODE: CL280A (LOOSE)

THERMAL PROTECTIVE AID (TPA)

The TPA is designed to aid survival in lifeboats and liferafts, and in other situations where life is threatened by loss of body heat.

- Module D certification.
- Fitted with hood and zipper.
- **Folded Size:** 20 x 30 cm (7.8 x 11.8")
- **Weight:** 270g (9.5oz)
- One size fits all



CODE: MF206B





GUARDSMAN HANDWARMER

Ideal for outdoor activities on cold days or for night work.

Each rod provides heat for approximately 9 -10 hours when lit at a single end, or for 4 - 5 hours when lit at both ends.

Once the rod is burnt out, the remaining ash can be emptied out and the new heating rod placed inside.

Each case is supplied with 12 fuel sticks (also available separately).

Size: 11.5 x 7 x 2cm (4.5 x 2.8 x 0.75")

Weight: 100g (3.5oz)

CODE: CL283 (HANDWARMER WITH 12 FUEL RODS)

CODE: CL284 (SOLID FUEL REFILLS X 12)



WILDLIFE™ INSECT REPELLENT

DEET 40% CITREPEL 0.1%

Wildlife insect repellents provide protection against mosquitos, gnats, midges, horse flies, ticks, tsetse flies and most other biting insects.

- Available as a compact handy stick
- Long lasting (up to 10 hours)
- Sold in an attractive display box of 24 units

weight: 25g (0.8oz)

Size: 8cm x 2cm (3" x 1")

CODE: CL127

Shark Repellent

BCB shark repellent contains a chemical and a thick black dye that repels and disorients sharks.

When tested by the US Navy in 1967 BCB's shark repellent was the only product out of 24 to achieve any success in repelling sharks. Since then BCB's shark repellent has been used by Navies worldwide as their approved shark repellent.

When this foil packed sachet is squeezed in water, the crystalline acetate produces a dense black cloud. The inner bag has an attachment cord so it can be kept close to your body. This NATO approved product is used in life rafts and for airborne survival packs.

- **Weight:** 115g (4oz)

Code: MM208

NSN: 6850-99-220-3539





ZIPPED DAYSACK DRYBAG

A large watertight and airtight bag. Manufactured from strong 500 denier PVC and has welded seams for extra reinforcement. The YKK high compression Aquaseal dry zip is protected with PU tape. Adjustable, padded shoulder straps and is load tested to 100 kg, including the lift strap between the shoulder straps.

Colour: Black

Size: 62 x 39 x 24cm (24.4 x 15.3 x 9.4")

Weight: 0.85kg (1.8lbs)

Volume: 60 litre (105.5pt)

CODE: CA153 (60 LITRE)



SNAP-SEAL BAGS

Water tight protective bags.

- Pack of 10 includes: 5 large, 5 small

Size (large): 53 x 58cm (21 x 15")

Size (small): 38 x 25cm (15 x 10")

CODE: CL006 (PER PACK OF 10)

Contents not included



ULTRALIGHT DRY BAG

Ultralight Dry bags can be used to organize your kit on any trips. The fully taped Ripstop PU coated fabric keeps the weight down and helps keep your kit safe and dry. A durable buckle secures the roll-top closure and acts as a grab handle.

- Ultralight, waterproof 40D Ripstop nylon
- Silicone PU coated fabric
- Waterproof taped seams
- Roll-top waterproof closure
- Durable buckle secures roll top

Capacity	Colour	Code
1 LITRE	Yellow	CA965
4 LITRE	Red	CA966
13 LITRE	Blue	CA967
35 LITRE	Black	CA968



60 Litre & 90 Litre Dry Bag

A fully submersible dry bag manufactured from hard wearing coated nylon. Features a roll-down closure with quick release buckle.

Code: CL081 (60l)

Code: CA960 (90l)

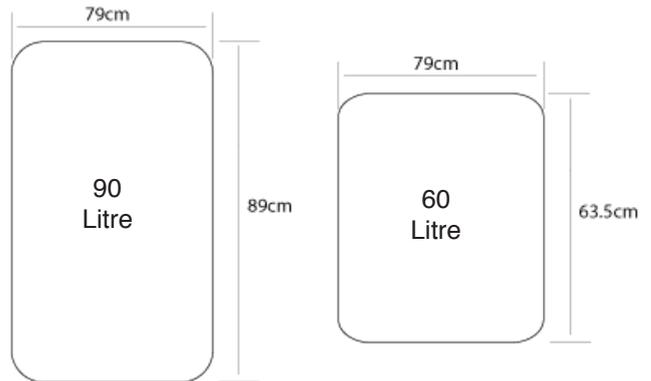

MEDIUM FIELD CHEST - VOLUME 28.5 LITRE

- Can be padlocked
- Fits inside the empty large case for easy storage and transportation
- Waterproof

Outer Dimensions: 479 x 415 x 217mm (18.85 x 16.33 x 8.54")

Inner Dimensions: 448 x 345 x 186mm (17.63 x 13.58 x 7.32")

Weight: 5.18kg (11.41lbs)

Case Material: Engineer resin and Glass fiber

NATO approved: NSN-8145-99-163-6427

Tested to: EN4875 Part 7

CODE: FF010



LARGE FIELD CHEST - VOLUME 84 LITRE

Robust, lightweight and space efficient case.

- The small case fits inside the larger case
- With 2 wheels and retractable handle
- Supplied without foam
- Waterproof
- Can be padlocked

Outer Dimensions: 670 x 508 x 355mm (26.37 x 20 x 13.97")

Inner Dimensions: 584 x 442 x 329mm (22.99 x 17.40 x 12.95")

Weight: 10.92kg (24.07lbs)

Case Material: Engineer resin and Glass fibre

NATO approved: NSN-8145-99-429-7464

Tested to: EN4875 Part 7

CODE: FF011



RESCUE LOCATION LASER

- 5 Hour Laser Emergency Signal Device
- Equal to 300 x 1-minute flares
- Signal up to 48km (30 miles)
- Waterproof to 24 metres (80 feet)
- No Fire Hazard
- Environmentally Safe
- Effective in daytime at reduced distances.
- Locate reflective material up to one mile (1.6km) away.
- Non flammable, Non hazardous
- Rugged, machined aluminium anodized to prevent corrosion
- Long life laser diode - 5,000 hours meantime to failure

Weight: 78g (2.75oz)

Power Supply: One 3V CR123 lithium battery gives approx. 5 hours operating time.

Wavelength: 532nm

Size: (12 x 2.24cm) (4.72" x 0.88")

CODE: CE099

COMBAT ZOOM FLASHLIGHT

- High, Low and Strobe Modes
- Adjustable beam - wide or focussed
- Light Source CREE LED light chip
- Slide Focusing Head patented slide function
- Over 100 metres Beam Distance
- High grade aluminium alloy body
- End Cap Switch easy access recessed rear mount power button
- Removable Pocket Clip
- Rubberised Tooth Guard
- Waterproof

Length: 10.5cm (4") adjustable to 11.7cm (4.6")

Weight: 53.8g (1.8oz)

Lumens: 130

Runtime: 5 hours

Batteries: 1 x AA (Battery not included)

CODE: CE024W



← Slide head to switch between focussed and wide beam

SIRIUS HEADTORCH

- Stable and comfortable to wear
- 3 Modes: High, Low and SOS
- Waterproof to IPX-4
- Distance: 120 meters (393.7 Feet)
- LED: CREE XP-G2 R5
- Lens: Anti-scratch Polycarbonate
- Switch: Magnetic
- Impact Resistance: 1 meter drop test
- Duration: 5 hours @ 225 lumen output or 47 hours @ 20 lumen output
- Strong nylon and Bolivai Filament casing

Dimension: 38cm (14") (head dimension)

Weight: 112g (3.9oz)

Batteries: 3 x AA (not included)

CODE: CE046



FFLAM TORCH MKII - NEW

A new lighter weight waterproof torch. The rubberised outer coating protects this from the worst of maritime environments.

- Fully waterproof and approved flashlight
- Uses 2 x AA batteries (supplied)
- With morse code signal button.
- Strong and impact resistant.
- Approved to ISO 18813
- Over 100 candela after 5 hours

Supplied with a replacement LED head contained in a separate case.

Size: 16 x 4.5cm (6.2 x 1.7") head dia.

Weight: 90g (3.1oz) (empty)

Batteries: 2 x AA batteries (supplied)

CODE: MM306



FFLAM Torch Original

- A strong waterproof rubberised signaling torch.
- Compact SOLAS approved rubberised coating protects this torch from all of the elements.
- Designed for life rafts and lifeboats
- The Fflam torch has a morse code signaling button.
- The Fflam torch has successfully undergone immersion tests and 36 metre life raft drop test.

- Type Approved
- Takes 2 "C" cell batteries
- Weight: 295g (10.4)
- Dimensions: 15.5 x 4.5cm (6.1 x 1.7")

CODE: MM305 Torch only

CODE: MM306 + Spare bulb

CODE: MM308 + Spare batteries

and spare bulb (TYPE APPROVED)

CODE: MM309 As MM308 but with alkaline batteries for extended shelf life (TYPE APPROVED)



MEDICAL

SURVIVAL

RATIONS

PROTECTION

LOCATION

SEARCH

SECURITY



MAP READING COMPASS

A base plate compass, containing a magnifying glass, ruler and scales for 1:25000 and 1 mile to 1 inch. The liquid filled compass rotates within the base.

- Nylon lanyard included
- Stencil holes for adding map symbols

Weight: 53g (2oz)

Size: 15.5 x 4.5cm (6" x 2")

NATO approved: NSN-6605-99-501-14968

CODE: CK602



COMPASS 4 MILITAIRE

The "full-size" base plate compass for experienced navigators. Contains everything you need in a compass and has added functionality for GPS. The Expedition 4 is used by many defence forces around the world

- Compass housing made from Dryflex™ - rounded base plate – comfortable and fits any hand size
- Patented red/black orienting lines – easy and "fool proof" to take bearings
- Map measuring scales mm, inch Romer scales, 1:25k, 1:40k, 1:50k – compatible with basically any map.
- Luminous markings - enables night navigation
- Friction feet – increases precision in map work
- Hole for marking positions on map with pen pencil – increasing precision
- Built in magnifier for detailed map reading

CODE: CK406



MINI COMPASS II

An extremely compact and accurate button compass. Features a rotating bezel and a clear acrylic base plate.

- Nylon lanyard included
- Oil filled and cushion mounted
- Luminous dial

Weight: 8g (0.28oz)

Size: 3 x 5cm (1" x 2")

CODE: CK315

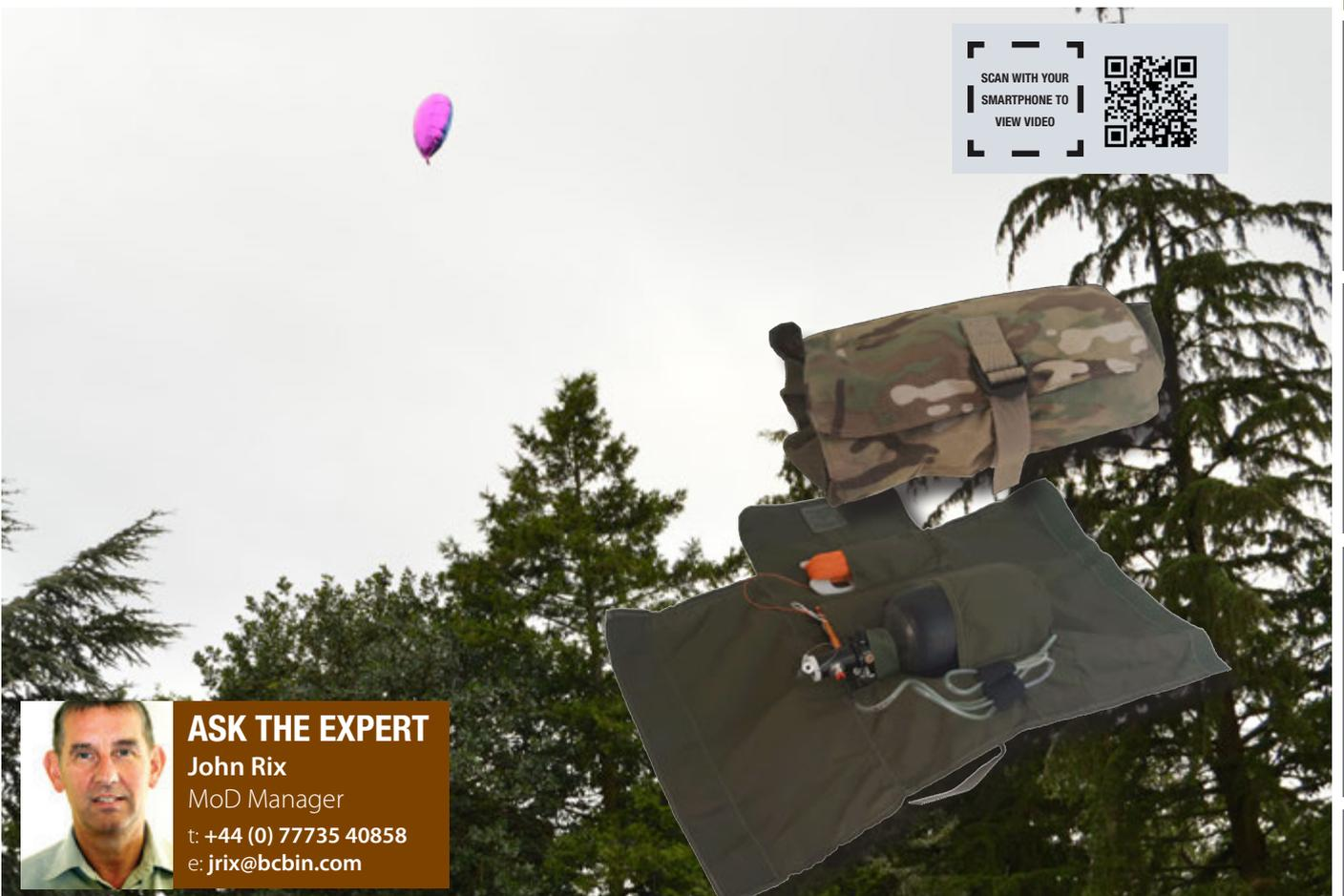

ASK THE EXPERT

John Rix

MoD Manager

t: +44 (0) 77735 40858

e: jrix@bcbin.com

LOCATION MARKER BALLOON CODE: CK409H

A ground to air signal balloon.

Designed by the military for the military.

- Quickly deployed in under 2 minutes
- Lightweight carbon fibre large capacity helium cylinder
- Large (over 1 metre) bright balloon
- Day or night time visible. Attach a chemical light (two supplied)
- Radar reflective
- Reusable
- Lightweight and safe to use
- Can be quickly used to mark your Drop Zone position or if in need of rescue.
- Will float high above any jungle or forest
- 75 metre (250 feet) strong kevlar tether
- Can be operated by one person within minutes
- Uses inert helium gas to inflate 136 litre Radar Reflective balloon
- Two chemical light disks (supplied) can be attached to both sides of the balloon giving at night an excellent signal, especially if the pilot is wearing NV goggles
- Can be seen over 10 miles away
- The balloon will stay aloft for many days
- Can be pulled back down and released back up as required
- The balloon has an excellent lifting capacity and can take up approximately 80 gms i.e. a radio antenna etc above the canopy
- Also very effective in other distress environments, e.g. maritime, desert and woodland etc
- The foil balloon gives a large radar reflective signature (over 10 metres)

Packed size: 39 x 25 x 12cm (15 x 9.8 x 4.7")

Balloon open size: 119 x 66cm (46.8 x 25.9")

Weight: approx 900grams (31oz)





Scan with your
smartphone to
view video



Mayday Signaling Mirrors Heliograph

This innovative mirror is lightweight. Robust and approved for marine and military use. It is highly reflective giving it a range of over 9 miles, for the small mirror and longer for the liferaft/lifeboat larger mirror. Designed for one-handed operation.

- Accurate and effective
- Floats
- Robust lanyard attached
- Quick and easy to use
- Instructions printed on reverse side
- Useful as personal travel mirror

CODE: RP314 5 x 5cm (2 x 2")

CODE: CK324 10 x 10cm (4 x 4")

NSN: 6350-99-613-9818 - compact

SOLAS APPROVED



Stainless Steel Heliograph

- Stainless steel heliograph
- Highly reflective
- Very tough and durable
- Available in 5 x 5cm (2 x 2") or 10 x 10cm (4 x 4")

CODE: MF600 2"

CODE: MF601 4"

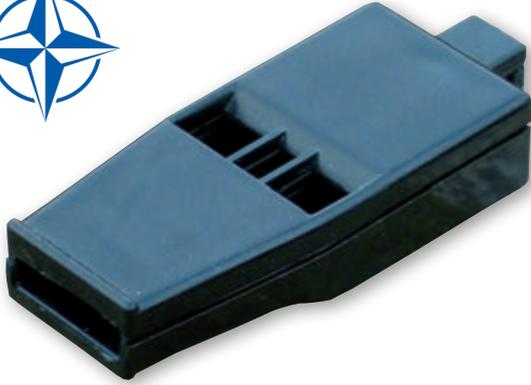

Howler Whistle

An incredibly loud whistle. Compact with no moving parts. This British made whistle is used in our Special Forces survival kit. Used also by mariners and sports people.

- **Size:** 2 x 5cm (0.75" x 2")

Code: CK316



Distress Whistle

Bright orange emergency distress whistle. Produces a high decibel noise from low air input.

- Side clip
- SOLAS approved

Code: RP312

NSN: 4220-99-120-9470

Throwing Quoit+Line

- 30 metres (98.4 ft) length
- Diameter 170mm (6.7")
- Floating Line + Quoit

CODE:MF20S - Quoit

CODE:MF20SB - Quoit + Line



Light Sticks

Excellent for emergencies, and as a location indicator.

- **Size:** 15 x 1.5cm (6" x 0.5")
- **Weight:** 20g (0.75oz)

Colour Duration Per 10

CODE: CE571R Red 12 hrs

CODE: CE571G Green 12 hrs

CODE: CE571W White 8 hrs

More colours available on request

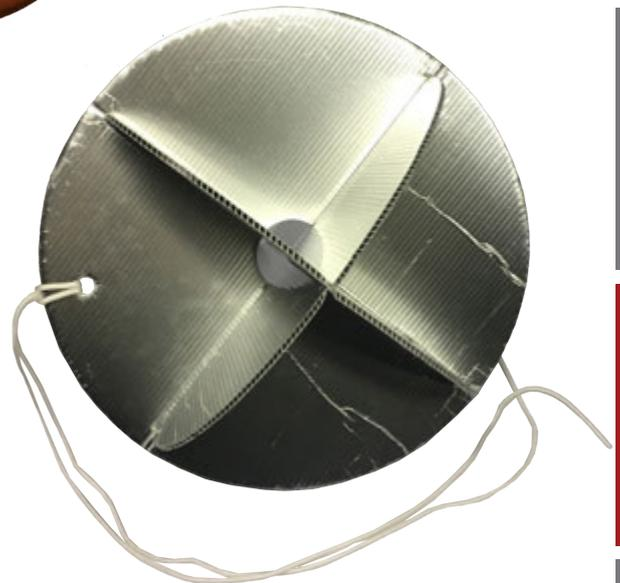

Inflatable Radar Reflector

- UK MCA (SOLAS) Approved.
- Made fast to the raft by using an optional telescopic rod.
- Inflated diameter 620mm.

CODE: MF731

CODE: MF730 (with rod)

Search - Rescue

Rescue Cradle

The Fibrelight Cradle is a new and versatile man overboard recovery system designed primarily for use by small rescue craft, rigid inflatables ships' lifeboats.

Manufactured from PU coated polyester webbing and reinforced with carbon fibre rods, the Fibrelight Cradle is tough, durable, lightweight and easy to handle; it is 1.3m wide by 3m long and weighs approximately 5kg.

The Fibrelight Cradle has many different applications however its primary function is that of a system recover casualties from the water in the medically preferred horizontal position. To rescue a casualty in this way the cradle is secured at the inboard end and the outboard end is held outwards by hand, boat hook or bridle depending on the size of the craft.

The casualty is then guided on the cradle and the outboard end is hauled up, bringing them safely on board. Once recovered the casualty can be kept in the cradle if necessary, for use as a stretcher.

In addition to this application the Fibrelight Cradle can be used as a scramble net or boarding ladder to climb into the boat or disembark safely in an emergency, and can assist with casualty recovery from trenches, ditches and other similar locations.

- SOLAS approved

CODE: MF809



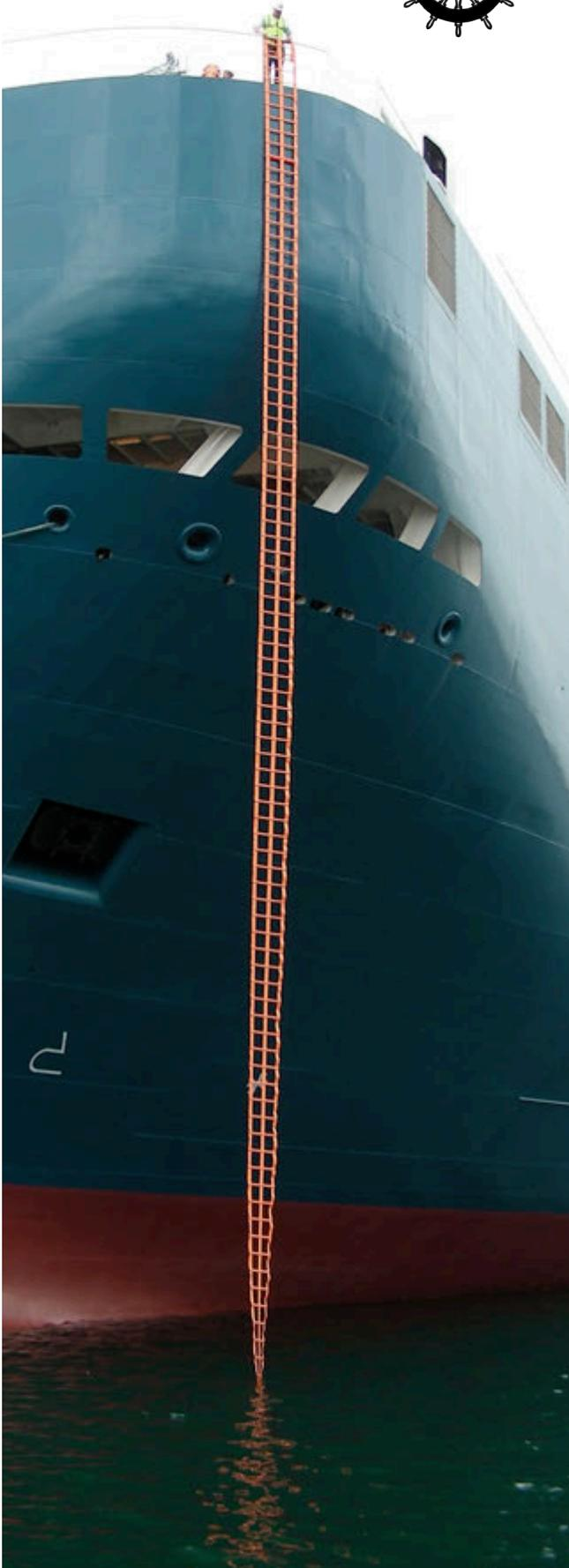

The Fibrelight Emergency Ladder

This is a strong durable device in use across the world on merchant ships, offshore support vessels, navy warships, super yachts and on land in overhead cranes.

The ladder has been designed for use in emergencies, it can be carried and then deployed by a single person in less than a minute, as it is both lightweight and straightforward to use.

The ladder is a standard width of 600mm and is produced in lengths of 2 - 30metres, in either Orange or Black. The ladder contains no metal parts and therefore is suitable for deployment on vessels or platforms with fire risks. A 30-metre ladder weighs less than 30 kilograms. With a natural step action the double rung ladder is considerably easier and safer to use. The ladder is both faster to climb and more importantly to descend than a single rung ladder.

KEY FEATURES:

- SOLAS approved
- MCA accepted
- Lightweight
- Portable
- Can be loaded in either direction
- No annual servicing required

SPECIFICATIONS:

- Diameter** – 600mm
- Lengths** – 2m up to 30m
- Weight** – 0.9 kg per metre
- Safe working load is 900 kgs

CODE: MF807C

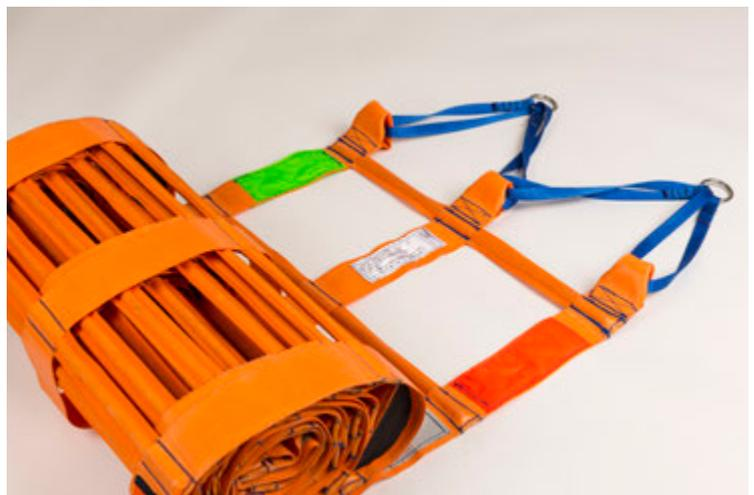

MEDICAL

SURVIVAL

RATIONS

PROTECTION

LOCATION

SEARCH

SECURITY

RESCUE BRIDGE

The rescue bridge is an inflatable rescue path for accessing casualties during rescue on mud, ice as well as water rescue.

The rescue bridge can also be used as a bridge across rivers, streams or gullies

- Lightweight and easily portable
- The twin sponsors on the underside increase the stability in water and reduce the friction when used on mud
- Inflated from a single point for speed of inflation and air transfer valves are fitted between the path and the sponsors to isolate the separate chambers
- Quick and easy to deploy
- Non slip top surface
- Strong and durable for a long service life
- Reflective tapes are fitted for night time visibility
- Can easily be connected end to end used sideways to create a rescue raft
- Can be used as a temporary pontoon, rescue raft, platform or access path
- Stowage pockets are fitted to the end of the each containing a rescue line and rubber ring
- Lifelines fitted to all sides
- Towing points fitted to both ends



RESCUE BRIDGE

Used For:

- Mud Rescue
- Flood Rescue
- Ice Rescue
- River Rescue
- Casualty Recovery
- Unstable terrain

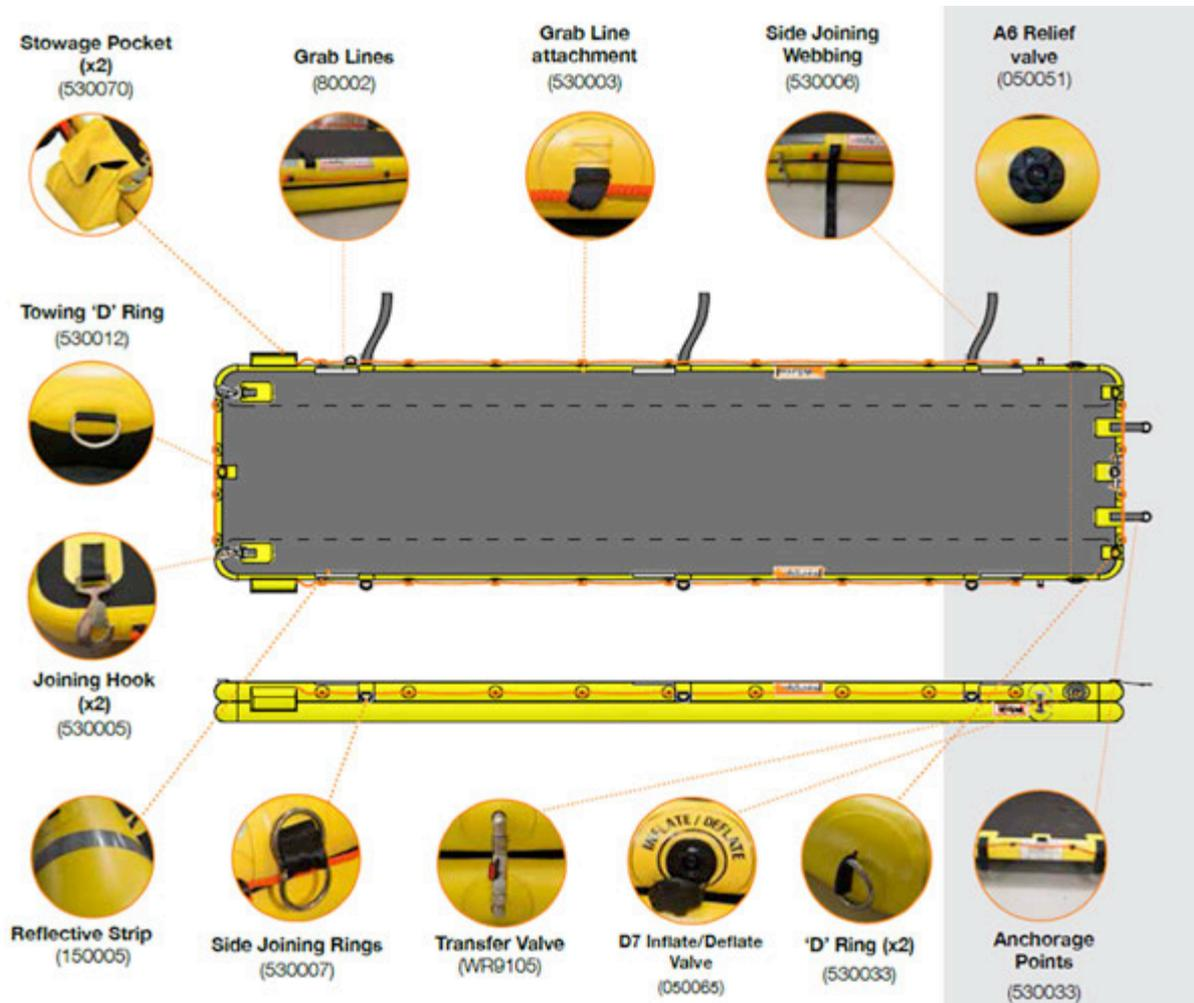

CODE	MF0011	MF0012	MF0013	MF0014	MF0015
Length (M)	2	3	4	5	10
Capacity (Kg)	200	300	400	500	1000
Pack Size (cm)	82x48x24	87x48x28	87x48x32	87x48x35	89x73x50
Weight	12	17	22	28	55

INFLATABLE RESCUE CUSHION FAST DEPLOYMENT - RAPID EVACUATION - INFLATION 30 SECONDS - RECOVERY 10 SECONDS

The Inflatable Rescue Cushion is ideal for rescuing persons when it is not possible to use a ladder. The unit is very fast to deploy and facilitates rapid evacuation. It is very stable, there is almost no bounce-back, the cushion always deforms towards the centre and it is easily transported whether packed or inflated.

The Inflatable Rescue Cushion comprises an inflatable frame which supports a high strength, flame retardant PVC coated fabric. Inflation is from a 300 bar air cylinder, the connection for which will be compatible with the brigade standard. Relief valves are fitted to prevent over pressure but the operating pressure of the tubular framework is sufficiently high to ensure extended service periods without topping-up.

As the frame inflates air enters the cushion, which is divided horizontally into two chambers, through vents in the side walls. The force of a person landing on the cushion temporarily deforms it towards the centre. Air from the cushion (but not from the tubular frame) is forced out and so the impact is absorbed. On removing the person the cushion recovers its form within a few seconds.



ASK THE EXPERT
Phil Jones
E.U & MOD
t: +44 786 631 3278
e: pjones@bcbn.com



- The Inflatable Rescue Cushion can also be used to rescue pilots escaping from cockpit windows on burning aircraft or for aircraft without escape slides.

- Surface Conditions:

The Inflatable Rescue Cushion may be placed on almost any surface including gravel and kerbstones, although very sharp objects and glowing embers should be avoided.

- Moving the Rescue Cushion:

Carrying points on all four sides enable even the largest inflated cushion to be easily moved and finely positioned.

	SP 16	SP 23	SP40
L X B X Ht	3.5 x 3.5 x 1.7 m	4.5 x 4.5 x 2.3 m	8.5 x 8.5 x 3.7 m
Ground required	3.8 x 3.8 m	4.9 x 4.9 m	9 x 9 m
Deployment	2 persons / 30 secs	4 persons / 60 secs	4 persons / 120 secs
Max Jump	16 m	23 m	40 m
Recovery time	10 secs	20 secs	20 secs
Inflation	1x 6L / 300 bar cyl	1x 8L / 300 bar cyl	5x 6L / 300 bar cyl
Connection	As brigade standard air cylinder		
Weight	55 kg (with cyl)	80 kg (with cyl)	250 kg (with cyl)
Packed	900 x 550 x 300 mm	1250 x 650 x 500 mm	1700 x 950 x 750 mm
Compliance	DIN 14151, 1-3		

Code: **CT096** **CT097** **CT099**





CLEARANCE DIVER DRYSUIT

This completely non magnetic neoprene drysuit is supplied to the UK Royal Navy Clearance Diving teams.

Other tasks include work on small mine hunting vessels as part of a diving team searching for and destroying enemy sea mines. Specialist shore diving teams are also involved in clearance of areas of surf in preparation for amphibious operations. All of these operations pull together to provide Littoral Maritime Manoeuvre. Divers, Mine hunters and survey vessels ensure important shipping lanes are kept clear during times of conflict.

The clearance diving suit is worn to conduct bomb and mine disposal tasks underwater.

- Rear entry heavy-duty 6 pitch non magnetic zip with protective cover
- Manufactured from ultra-tough, hyper compressed 4mm neoprene with pique outer lining
- Non-magnetic fly zip with zip cover for additional protection
- CE approved non-magnetic inflation & exhaust valves
- Over sized DuPont™ Kevlar® reinforced kneepads
- Rubber taped and bonded for life seams
- Choice of superstretch neoprene or latex neck and wrist seals
- Arctic black extreme hood with supervent

Choice of pocket and positioning as required (bellows pocket shown)

Available in 17 standard sizes which are specially made to measure and tailored to fit perfectly.

CODE: MF814



DELTA NEOPRENE WETBOOTS

Manufactured from super-flexible 5mm Neoprene, Northern Diver wetsuit boots have a unique Titanium lining, for fantastic heat retention and additional comfort.

These wetsuit boots feature a durable YKK side zip, for ease of use, a rugged anti-slip rubber sole and incorporate additional protection around the heel and toe areas.

Perfect for beach use, boat trips, diving and snorkelling.

CODE: MF830 (BOOTS)

CODE: MF819B (FINS)



ANKLE WEIGHTS

Heavy-duty nylon ankle weights, with Fastex buckle fastening, allow divers to fine-tune ankle weighting by using lead shot. Ankle weights improve stability by altering centre of mass.

Size Small - Maximum Capacity 0.4kg

Size Large - Maximum Capacity 0.7kg

NATO Approved: NSN - 4420 - 99 - 0830966

CODE: MF823S (SMALL)

CODE: MF823L (LARGE)

SEABORNE

Gaining entry to a vessel at sea or in harbour is a covert tactical of ingress used the world over. The easiest MOE is a Wire Ladder attached to a grappling Hook, put onto the side of the vessel using a Swimmers or Wind Up Pole. As it's a covert MOE at sea it's difficult to photograph, but hopefully this summary helps. The poles are buoyant and accessories are black or dark green.

- Hooks are available in over half a dozen shapes.
- Ladders are available in 5, 10 and 15m length.
- Pole closed and extended lengths range from up to 3m to >7m to >4 to 15m, with various options on diameters and weights.



Security - Body Armour Floating



Scan with your smartphone to view video



This innovative system provides comfortable armour with an integrated life jacket. The removable inflatable stole is located underneath the high performing level IIIA armour pack. This protects the wearer and the life jacket from bullet or fragment threats. Having the lifejacket under the body armour also gives it a low profile close fit. Other body armours with a neck external lifejacket catch on the helmet. The gas inflatable stole is kitted out with an automatic trigger which deploys within seconds in water. The armour vest expands around with the bladder when activated to provide continuous protection. Extensively independently tested.

- Available with a 175 Newton and a 275 Newton floatation capability.
- Tabard style tactical armour vest
- Fully functional all-round MOLLE system to suit the task in any terrain
- Removable inflatable lifejacket (Stole), with a choice of 175N or 275N capability
- Vest expands with the inflation of the stole
- Self rights the wearer to clear airways from the water
- Adjustable at the sides
- Internal elasticated waistband distributes the load of the vest
- Rear grab handle facilitates emergency extraction
- Mesh lining for better airflow and rapid drainage
- Bladder is removable so the body armour can be used alone
- Easy access bladder for re-arming, servicing and cleaning
- Lightweight PU coated Nylon 500 denier outer fabric
- Removable and adjustable crotch strap
- Water resistant aramid used.
- Ballistic inserts made of low density and buoyant
- Inserts protected with welded lightweight waterproof covers
- Ultra High Molecular Weight Polyethylene (UHMWPE)
- Choice of protection tested in accordance to NIJ 0101.04 or NIJ 0101.06
- Front and back 10"x12" hard armour plate pockets.
- Protection level NIJ IIIA

- AUTOMATICALLY INFLATES WITHIN APPROX 3 SECONDS OF WATER IMMERSION
- LIFEJACKET CAN BE REMOVED IF NOT REQUIRED AND THE BODY ARMOUR CAN BE WORN INDEPENDENTLY
- UP TO 275 NEWTONS OF CYLINDER BUOYANCY CAN BE TOPPED UP BY MANUAL INFLATER TUBE
UNIQUE 4 POINT EXPANSION



Security - Body Armour Floating

AVAILABLE IN TWO FLOATING CAPACITIES:

AIRCREW OR VEHICLE CREW

175 Newton buoyancy for Aircrew and vehicle crew. Lower profile for use in confined space.

MARINES, NAVY AND COASTGUARD

270 Newtons for use during land assaults, ship boarding and general boat use. Large capacity for when wearing/ carrying a rucksack heavy belt kit and weapons.

Each size has two finishes:

MOLLE: More traditional

LASER CUT: Less snag

And in two standard colours. Black and multiple camo pattern. Other camo patterns and colours available subject to minimum order specification. Patents pending

AVAILABLE COLOURS



MULTICAM BLACK



Side flaps protect the side adjustment buckles and provides HYPALON for pouches etc.



Flap protects the shoulder release buckle

Flap protects the shoulder release buckle



Stand off ribs help air circulation

Shoulders are shaped to fit the shoulder angle

25mm female buckle

Garment edge is edge stitched

MEDICAL

SURVIVAL

RATIONS

PROTECTION

LOCATION

SEARCH

SECURITY

Security - Boat Stopping System (BSS)

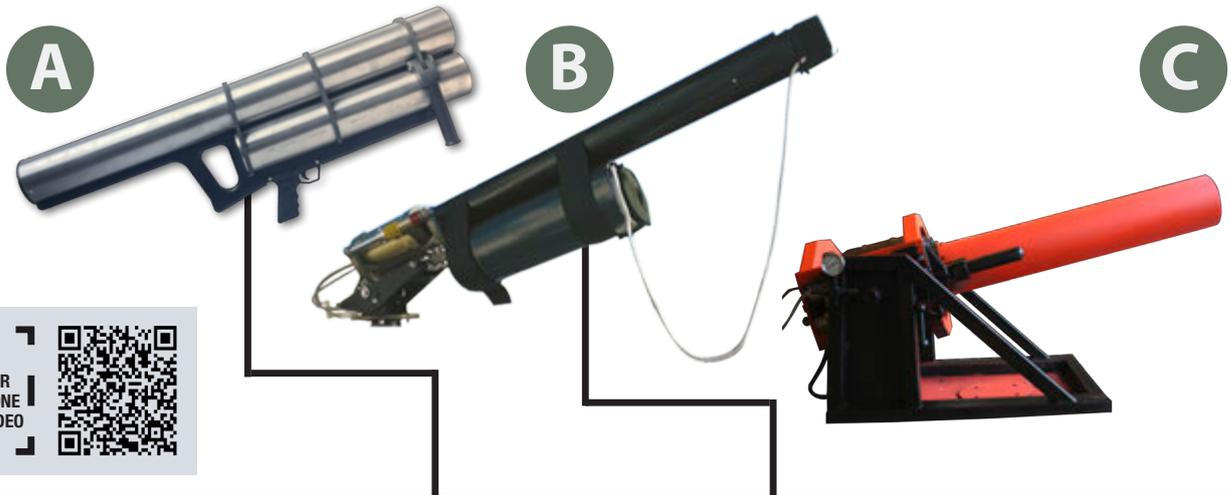

FEATURE	BARRACUDA (HAND-HELD)	BUCCANEER (SHIP BORNE)	SEA STINGER (PORT OR LARGER VESSEL)
Barrel diameter	5" (125mm)	5" (125mm)	7" (175mm)
Maximum range (approx)	40yds (36m)	200yds (200m)	437yds, 400m (line) 328yds, 300m (net)
Typical line length	40yds (36m)	100yds (100m)	218yds, 200m (line) 100m (net)
Typical barrel length	24" (50cm)	48" (1.2m)	48" (1.2m)
Max operating charge	11bar (160psi)	40bar (600psi)	40bar (600psi)
Total weight	28.6lbs (13kg)	72lbs (33kg)	430lbs (195kg)
Dimensions	6" x 52" (15cm x 130cm)	47" x 11" (117cm x 27cm)	59" x 23" (147cm x 57cm)
Suggested application	For hand-held use on or off shore. Use in confined waterways.	This medium launcher can have a single or twin V shaped barrel fitted. For use on all sizes of vessels from RIBS to capital ships to merchant vessels. Can be used to fire a line for ship to ship or ship to shore.	For closing quickly a port, harbour or estuary or for non lethal protection of a navy, coastguard vessel or oil rig. To protect any maritime assets.

Barracuda

Code: BARR001

A handheld device capable of launching a 36 metre (40 yard) arrestor line and two 3 ft (1m) sea anchors.

- Ideal for close-in interception
- Works in a variety of sea states
- Operates at a low pressure of 150 pounds per square inch
- Integral gas recharge bottle gives ability to reload and launch a second round quickly
- Comes in carrying case with two munitions



Security - Boat Stopping System (BSS)

Sea Stinger

Code: BUC002

The Sea Stinger is used as an 'Area Denial System' for large marine key point installations such as oil rigs, ports, estuaries or large cargo vessels that are vulnerable to acts of piracy or terrorism.

The 'big brother' of the Buccaneer the Sea Stinger is able to deploy entangling netting out to a range of 600 meters. Recover the line or net and re-use it again and again. Providing a non lethal deterrence and defence against incursions into vulnerable water ways and areas of sea the Sea Stinger is both simple to use and maintain.



MEDICAL

SURVIVAL

RATIONS

PROTECTION

LOCATION

SEARCH

SECURITY

Security - Boat Stopping System (BSS)

Buccaneer



Code: BUC001

The Buccaneer KIS delivers projectiles designed to deter and disable small fast sea craft at extended range.

With a range of up to 200 meters the Buccaneer KIS uses specialised payloads to lay buoyant netting / line for interdiction operations. The Buccaneer KIS is extremely flexible having a 360 degree rotation and depression and elevation of 45 degrees from the horizontal.

It can be operated remotely from the bridge or control room quickly and safely and uses no explosive or pyrotechnics parts in its use.

The Buccaneer can be loaded with alternative projectiles such as high density smoke, flares, or buoyancy aids.

Projectiles to either:

- Lay netting over a wide area
 - Lay a buoyant line or lines
- Or to entangle the assaulting crafts propeller.
- Dispense airburst smoke or an irritant gas
 - Dispense multiple small projectiles over a wide area – up to a 50 meter square – in a scatter gun approach

The projectiles:

- Non lethal – like paintballs
- Less than lethal – like squash balls
- Lethal – like gravel or golf balls

This provides a layered defense. The lethality can be increased if the approaching craft is not initially deterred.

Alternatively, it can deploy:

- Survival items to a man overboard like a single seat liferaft or buoyancy aids
- A rope line to shore for mooring, or to another vessel for towing



www.bcb.in.com · phone +44 (0)292043370

NSN:1095-99-993-1079





View the video



Buccaneer Light Weight Interceptor (LWI)

The non-lethal anti-piracy solution.

The Buccaneer Light Weight Interceptor (LWI) has been designed by BCB Marine to provide a non-lethal security solution to stop small, fast moving craft engaged in narcotic-trafficking, piracy and terrorist acts on open water, rivers and harbour areas.

Using compressed air, and no explosive or pyrotechnics, the Buccaneer LWI fires a specialised entrapment device which catches on a target vessel and applies up to 10 tonnes worth of drag against its forward momentum.

During rigorous and extensive trials and development, the Buccaneer LWI proved it is capable of bringing a twin 250hp engine 8 meter Rigid Inflatable Boat from a speed of 40 knots to a dead stop within a matter of meters.

The Buccaneer LWI is able to fire 200 meters of entrapping line, either to the side of the launching vessel, or directly ahead giving it unparalleled flexibility. The entire system is made of extremely robust and light weight composite materials making the Buccaneer LWI easily transportable from vessel to vessel whilst also able to withstand the harsh environment of the open sea.

Fitting options include either a fixed bespoke mounting system or 360 degree traversable mount utilising the popular Universal Gun Mount enabling operators to transition from a non-lethal posture to a lethal posture in minutes.

Each Buccaneer LWI is provided complete with an air pressure system as well as a fully recoverable and reusable entrapment system. BCB Marine also deliver full training on the Buccaneer LWI either in the UK or overseas ensuring that each operator is intimately familiar with the easy to use system.

Pricing options include additional spare equipment, extended system warranty and servicing program meaning that the Buccaneer LWI can be brought into operation and kept in operation with the minimum of effort.

Code: BUC003

Key Features:

- Light weight
- Simple to use and maintain
- Robust and weather protected
- Extensive range
- Remote activation
- Varied projectiles available
- Interchangeable on a UMG (Universal Machine Gun) mount
- Uses compressed air – no pyrotechnics
- 360 degree capabilities

ALTERATIONS AND AMENDMENTS:

Due to our continual product development, we reserve the right to alter or amend any product, specification or colour shown within without prior notice.

OTHER CATALOGUES AVAILABLE FROM BCB

MILITARY

FIREDRAGON

POLICE & SECURITY

FIREDRAGON

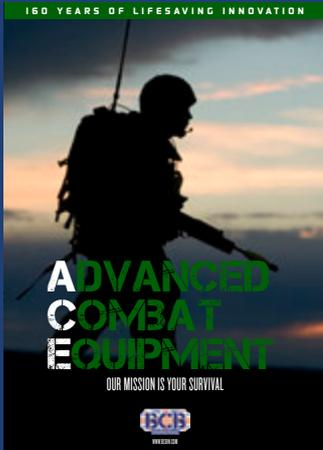

SCAN TO DOWNLOAD



SCAN TO DOWNLOAD



SCAN TO DOWNLOAD



SCAN TO DOWNLOAD



BCB Marine Ltd.

Howell House, Unit 1, Lamby Industrial Park, Cardiff, CF3 2EX

Tel: +44 (0)29 2043 3700 Fax: +44 (0)2920 433701 Email: info@bcbin.com

www.bcbin.com



The Queen's Award
for
Export Achievement
1986 • 1993

