

BCB International

Company Profile 2024



v32





Fabulous history



Brown's Cough Bottle = BCB As supplied to British troops in the Crimean war

BCB HISTORY



1854

Dr Brown invented Browns Cough Bottle (BCB) for the British troops in the Crimean War.



1900

Brown's Cough Bottle was sold to the public in the UK.



1914

BCB Ltd. was established as a medical company, named after Brown's Cough Bottle.



1940's

First ever medical kit for life boats and rafts were designed and manufactured.



1980's

First supply to the United Nations.



1979

BCB International Ltd was established to develop the military range and export.



1975

Supply of medical equipment to the first successful expedition to the South West face of Everest.



1967

Developed shark repellent for the U.S. Navy.

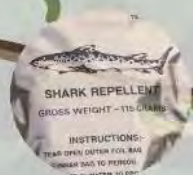

1950's

First supply to the British Ministry Of Defence

Brown's Cough Bottle Pastilles are made.



1988

Winner of first Queen Award for Export Achievement.



1985

Pioneer brand of outdoor accessories developed.



1993

LRQA ISO Quality Control approval.



1999

Robotic design begins.



2007

BCB International Inc. was established in the USA.



2009

Blast Boxes were designed.



2013

FireDragon eco-friendly cooking developed.



2014

BCB Adventure was set up for the outdoor market.

Meet the team

BCB International Ltd. Company Overview



CUSTOMER

SALES

MARINE SALES

Business Development



Stephanie Frieze-Davies
skf@bcbin.com

Business Development



Stuart Morris
sm@bcbin.com

Humanitarian



Fergus Lysaght
firedragon@bcbin.com

DEFENCE SALES

UK

Business Development



Maj John Richards
mod@bcbin.com

Head of UK Military Sales



Paul Ames
pa@bcbin.com

Business Development



Pete Botham
uksales@bcbin.com

UK Military Sales Manager



Viola Yaneva
ukadmin@bcbin.com

EXPORT

International Defence



James Wesley III
intsales@bcbin.com

ROW



Ben Simmons
bs@bcbin.com

Defence



Emily Howell
eh@bcbin.com

Sales Admin



Omnia Ahmed
row@bcbin.com

Ukraine



Julia Pas
reception@bcbin.com

Ukraine



Col (R) Volodymyr Riezniuk
ukraine@bcbin.com

Defence



Abigail Brunet
eudadmin@bcbin.com

RETAIL SALES

EU Leisure



Becky Ratcliffe
r@bcbin.com

Business Development



Paul Davies
pd@bcbin.com

Business Development



Morgan Jones
ukretail@bcbin.com

OPERATIONS

ACCOUNTS DEPARTMENT

Head of Accounts



Diana Rossi
dr@bcbin.com

Accounts Assistant



Kyle Seignot
fn@bcbin.com

Accounts



Jane Rees
jr@bcbin.com

PURCHASING

Purchasing Manager



Adnan Haddadi
ahaddadi@bcbin.com

Buyer



Chelsea Williams
j@bcbin.com

QUALITY CONTROL

Quality Manager



William Hudd
whudd@bcbin.com

Quality Assistant



Lesley Baker
lb@bcbin.com

Quality Control



Adam James
inspection@bcbin.com

OPERATIONS

Operations Manager



Lisa Owen
lo@bcbin.com

PRODUCTION

Production Manager



Sue Row
sr@bcbin.com

Camo creams



Leno Dinech

Packing



Steve Searl

Supervisor



Sarah Meah

Supervisor



Gareth Griffiths

Supervisor



Amanda Wilcox

ENGINEERING

Mechanical Engineer



Jonathan Swan
engineer@bcbin.com

Electrical Engineer



Robert Taylor
engineer@bcbin.com

DESIGN & DEVELOPMENT

R & D Manager



Lewis Thomas
rad@bcbin.com

R & D Designer



Alex Smith
design@bcbin.com

Chemistry



Katie Reichwald
chemist@bcbin.com

Graphic Designer



Ceri Darknell
graphics@bcbin.com

Junior Graphic Designer



Megan Jones
graphics@bcbin.com

COMMUNICATIONS

PA to Director



Kelly Humphries
asst@bcbin.com

DIRECTORS

Andrew Howell, MBE



Andrew Howell, MBE
arh@bcbin.com

Janey Howell



Janey Howell
janey@bcbin.com

TRANSPORT

Despatch



Gavin Jenkins
ra@bcbin.com

Despatch



James Brown
ra@bcbin.com

Goods In



Jay Hall
sc@bcbin.com



2 Modern manufacturing factories



**Secure 3-acre
freehold factory.
Close to city centre
And M4, (A48) motorway**



52,000 sq. ft. efficient factories



Officially opened
by
HRH Prince
of Wales





Prime British Manufacturer.

Eco fuel production - FireDragon



Camouflage Cream

Creams – liquids - powders



Sewing & heavy textiles



Kits & Packs



Responsive manufacturer



- ✓ **British quality**
= right first time
= sustainable
- ✓ **UK & EU standards**
- ✓ **Assured supply chain**

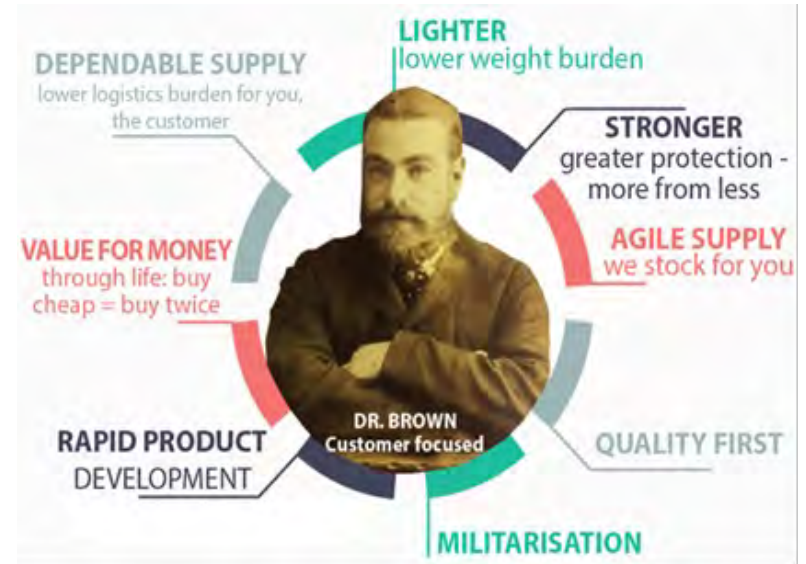

BCB pride ourselves on having the best products, ready and available to meet the needs of the rapidly changing military, political and social arenas worldwide. If new products are needed, we innovate, design and develop to bring solutions to market.



Focused growth markets

Well established customer relationships.

Respected brands

High quality innovative products

Defence 75%

Marine 13%

Outdoor 12%

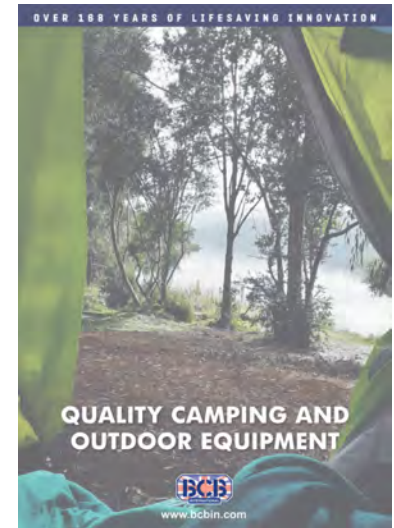
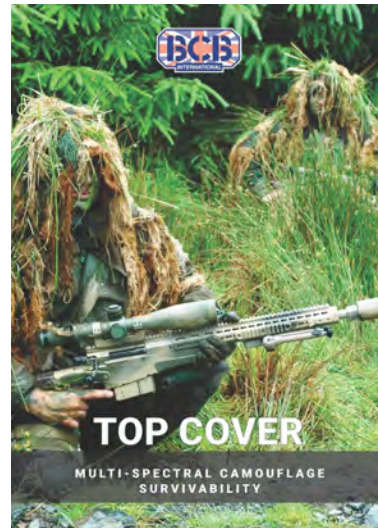

Core Markets

Delivery record = 95% on or ahead of time (KPI = 98%)



Quality Assured

QUALITY ASSURED
ISO Approved to since 1993

SOLAS approvals

LRQA
CERTIFIED

ISO 9001 · ISO 14001



ADS

- Accredited to ISO 9001:2015 & ISO 14001:2015
- ISO Approved to since 1993
- Over 400 N.A.T.O. approvals



Award Winning

- ✓ 2 x Queens Award for Export
- ✓ 3 x Soldier Technology Awards
- ✓ Best Company to work for, Sunday Times
- ✓ 2 x Welsh Innovation Awards
- ✓ Business Language Champion
- ✓ Special Recognition Award

MANUFACTURER OF THE YEAR





Impressive Customer Base

Good customer penetration throughout Europe Sales to over 50 countries with regular repeat business.

35% export sales

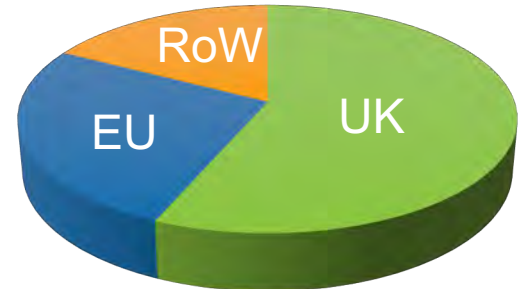

Global Sales

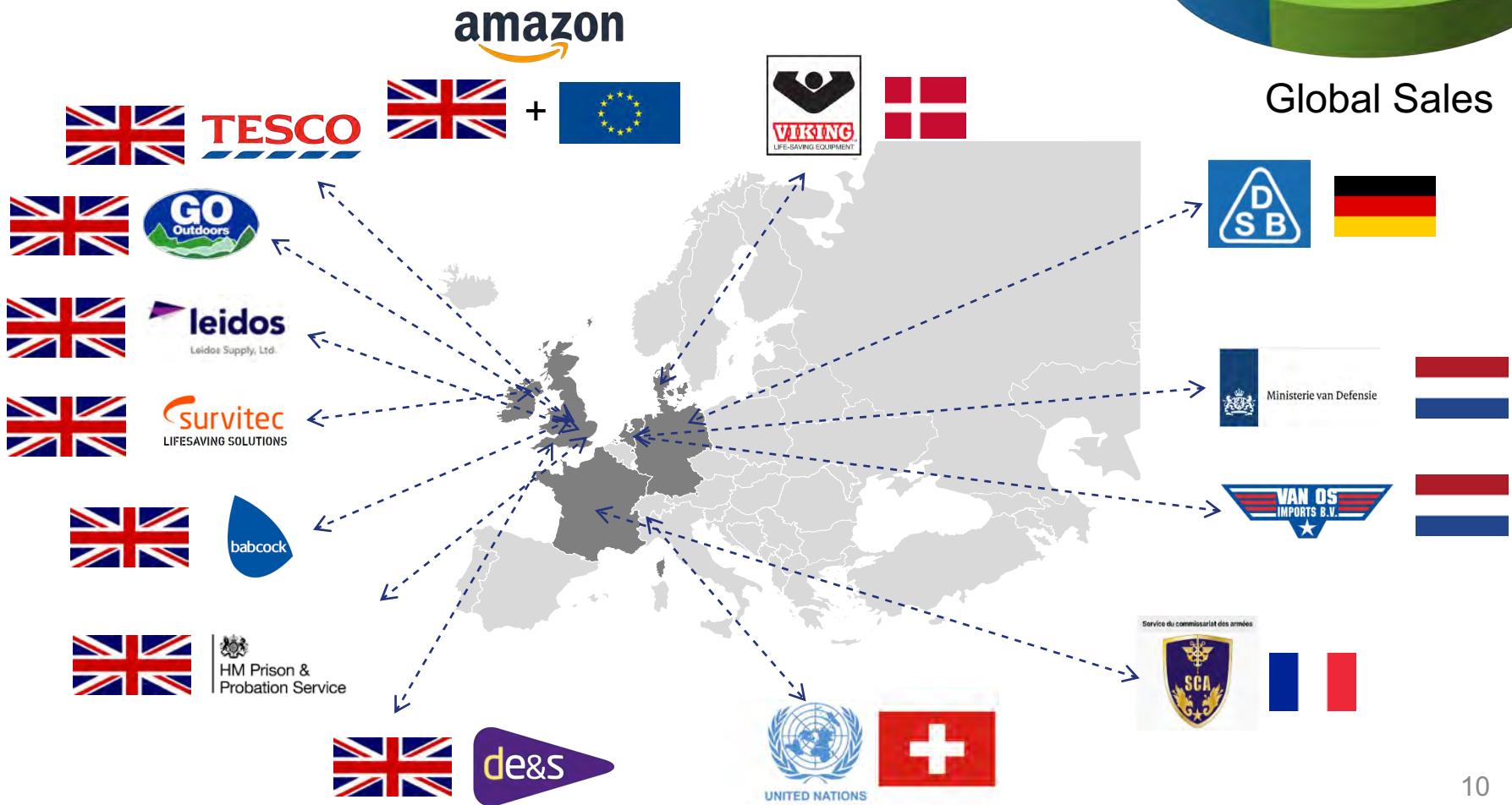

Quality Customer Base

PRIME CONTRACTOR

With long-term relationships across Military, Marine & Leisure sectors, including relationships lasting over 60 years with DE&S, the UK MoD, and RFD.





BCB Forward Figures

2 NEW + 2 REVAMPED RANGES

ACE	RETAIL	MS CAMO	UAV'S
-----	--------	---------	-------

CORE CONTRACTS LONG TERM @2-5 YEARS



£5M+P.A.

35% EXPORTS

50+ AGENTS

OUTSTANDING QUOTES £100M +

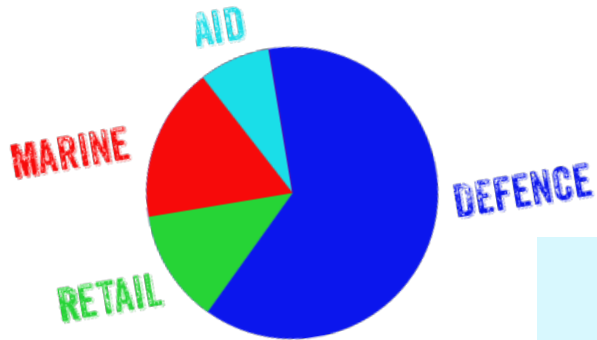

4 SOLID MARKETS

FORWARD ORDER

BOOK £3M

£1.29M INNOVATE GRANT

FOR PLANT IN UKRAINE BCB PART £407K

6x PATENTS

10x REGISTERED DESIGNS



✓ BCB = ESG



- Quality product made in Britain
- Supply Chain security by local re-shoring manufacture.
- So not let down by international supply restrictions
- Regular supply chain monitoring and closed managed.

- Local R&D = rapid product development with British Universities
- Family owned, managed, and friendly family feel
- UK taxpayer, exporter, and equal opportunities employer
- Cyber secure

FIRE DRAGON

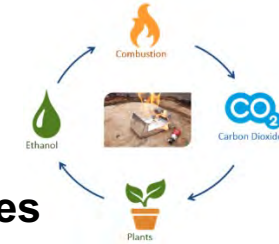

- **Have saved the many tonnes of CO, CO2, NO, PAH, methane and cyanide.**
- Prime manufacturer of clean green eco-friendly products
- Repair/refurbish capability = recyclable = *lower through life costs.*



- Regular supply chain reviews.
- **BCB is a fair and sustainable employer**
- Support local and international charities



Keep it local; make it British!



CANEI attitude = Continuous And Never-Ending Innovation

- Millions invested into R&D in the last few years
- Collaborative University and Business partnerships
- Diverse expertise.
- Rapid prototyping.
- Lifetime, invention, trialling, innovation and manufacture.
- Retired military personal

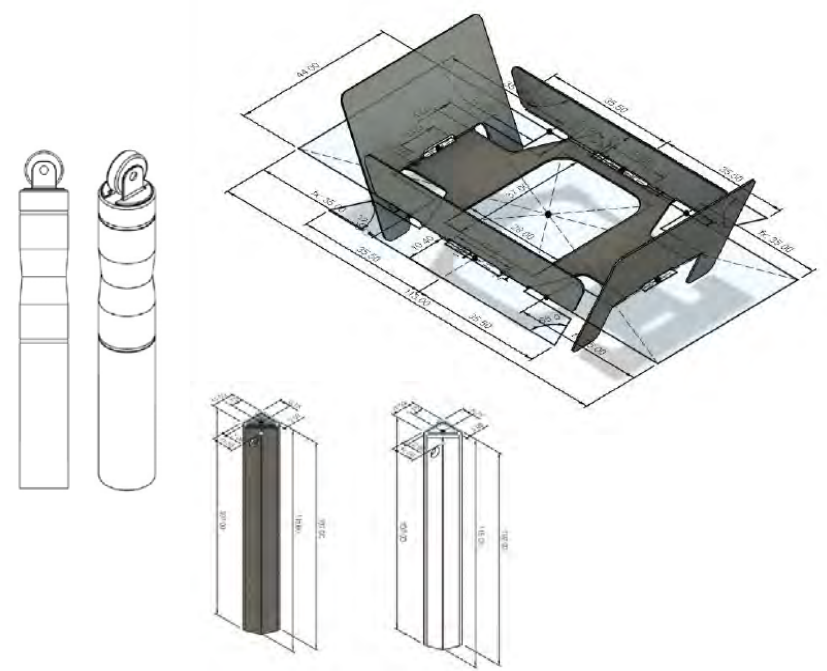

Some of our new or developing products



Mini Cooker MK2



Crusader Cup Lid



Folding Field Desk



Heating Kits



Solid Eco Fuel



Defence – core market

DELIVERY RECORD:
95% on or ahead of time
KPI = 98%

Highly innovative product range trusted by our military customers

Long history of serving the UK military market with the UK MoD and MoJ's as significant customers. BCB's owns the IP protection for 9 innovative products.

Command Tents



Field Furniture



Camo Nets



Fire Dragon Fuel + Cookers



Camo Cream



Floating
Armour Torso
Systems



Boat Stopping
System



IR Thermal
Camo net



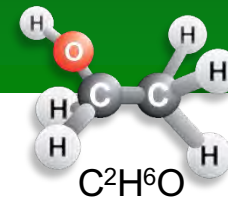

ECO FRIENDLY FUEL FOR THE FUTURE. GREEN & CLEAN

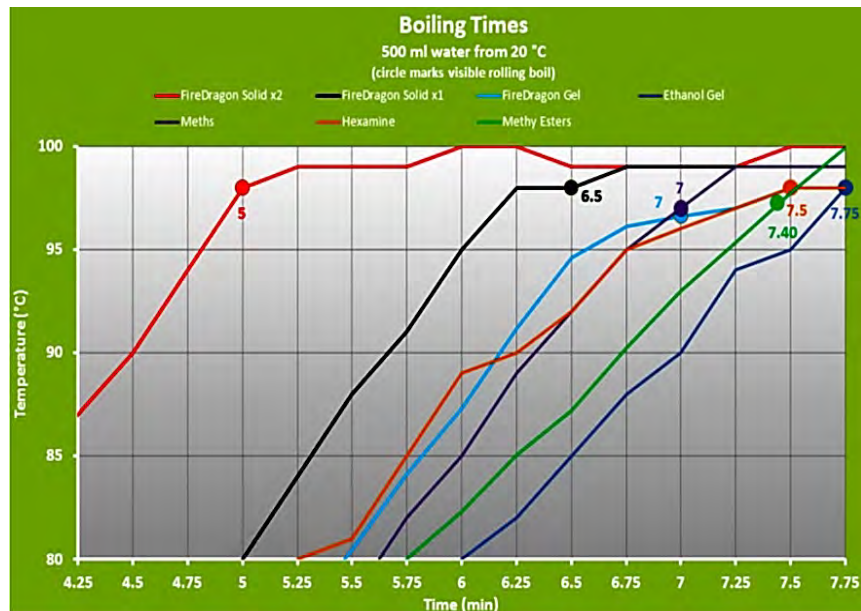

Fuel for the future

- ✓ Sustainable
- ✓ Cooks quickly
- ✓ Burns intensely
- ✓ Easy to light
- ✓ Nontoxic
- ✓ Safe to carry/transport
- ✓ Almost no soot produced



In extensive field and laboratory testing by the British Army, FireDragon proved to be the best of all solid fuels tested



Hand Cleanser



All-Weather



Quick & Easy to Light



Clean Burn

Water resistant and easy to ignite with a single spark

Environmentally-friendly solidified ethanol

Can be packed safely with food

Fast boil and long burn – high heat output

Clean burn; very few green house gases given off.

Air transportable

Safe to burn in enclosed spaces

Also effective as a hand sanitizer

Can be used in a range of existing cooking systems

Worldwide patent



"The small FireDragon tablets are easy to use and fit perfectly into my survival tin and mess kit"

Sgt, Special Forces

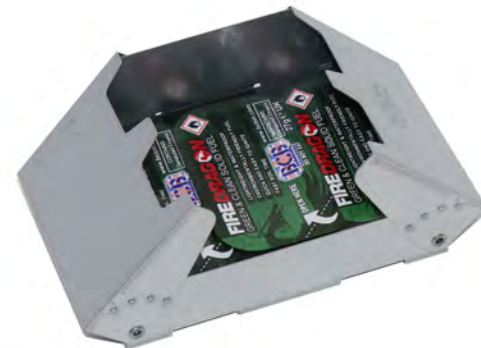

Non toxic. Natural ingredients

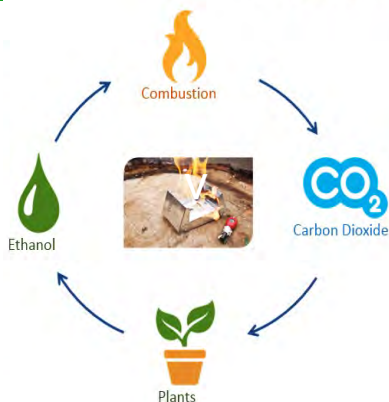

FireDragon is more efficient (28MJ/Kg) than kerosene, methyl esters and paraffin.





Field Cooking Systems & Eco Fuel

- Designed for efficient air intake whilst shielding against the wind
- Wind shield and heat exchanger
- Multi-fuel capability
- Fast boil time
- Compact, lightweight and robust
- Fast and efficient field cooking therefore low fumes, soot, CO, NO, CO₂ and Methane



**Works perfectly
with FireDragon
Eco fuel**





World leaders in Camo Cream

BCB manufacture for most NATO forces and are the global leader in camouflage cream.

- Non-irritant and non toxic
- Infrared Reflective (IRR)
- Available in compacts, sticks and tubes
- Not affected by rain or sweat
- Easily removed with soap.
- High sun protection factor



**We have been manufacturing camouflage cream for more than 35 years
Ours is the only cream in the world which is proven to be Infrared Reflective (IRR).**



Tube



Compact



30 & 60g Stick

BCB have made MK7 camo nets for over 15 years for the UK MoD in conjunction with The Ministry of Justice.

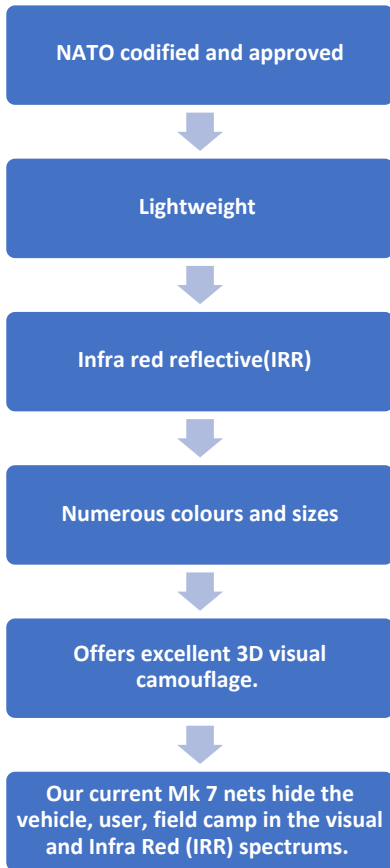

Our camo nets will camouflage/protect the user from modern thermal optics, which are currently being used to terrible effect in the Ukraine.

It will hide vehicles, field camps and personnel from the modern optics on their drones in the visual, near (NIR), short (SWIR), medium (MWIR) and long range infra-red (LWIR) spectrums.

A range of nets would be needed as no one net fits all climatic conditions or user needs.

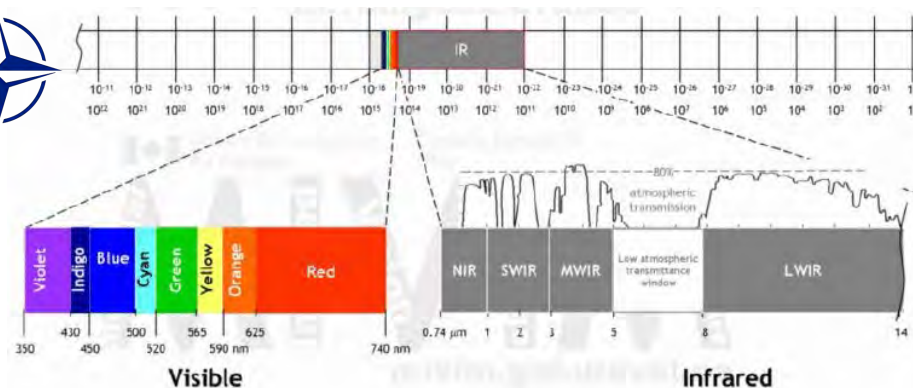

Infrared spectrum (400 – 1200)
Thermal spectrum • Visual spectrum

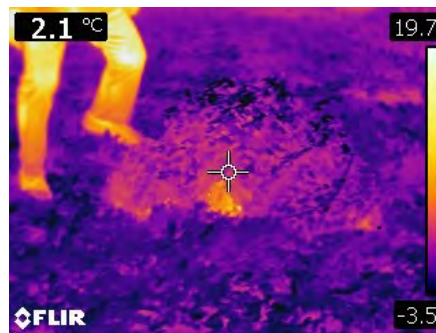

Above: Our subject lay under a sheet, looking out

Woodland Moorland / Mountain Desert Urban Snow



Patterns, colours and sizes can be customized according to customer requirements

The Mk8 is very effective from visual through hyperspectral to broadband/multispectral spectrums and gives an excellent emissivity reduction.



BCB's next generation MultiSpectral Cam (MSC):



- Camouflages in visual, thermal and infra-red spectrums
- Robust
- Lightweight
- Fire retardant
- Reversible
- 3D to break up outline
- Options for different terrains and sizes

Mobile camouflage



Platform static camo cover



Personnel

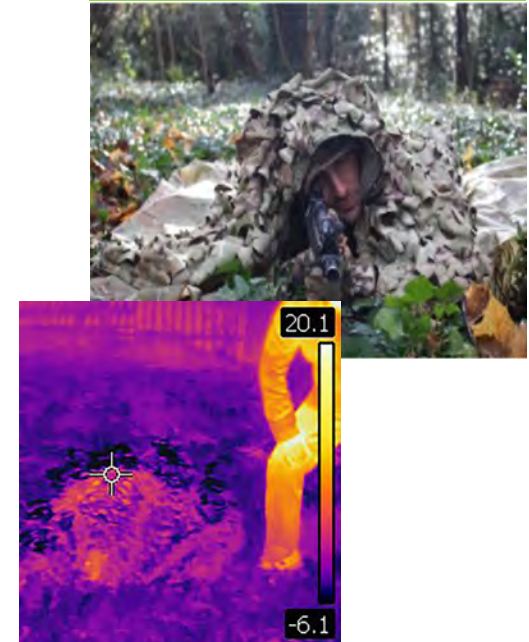

“Thermal Image (TI) Properties.

The ability of the CAMNET to conceal against TI was found to be excellent.

The image below was captured from a MOSQUITO thermal optic. Only the front portion of the HMTV is visible as the CAMNET was purposely raised to show a comparison between areas of the vehicle that are covered.

Note the net held in position by rocks due to the nature of the terrain.”

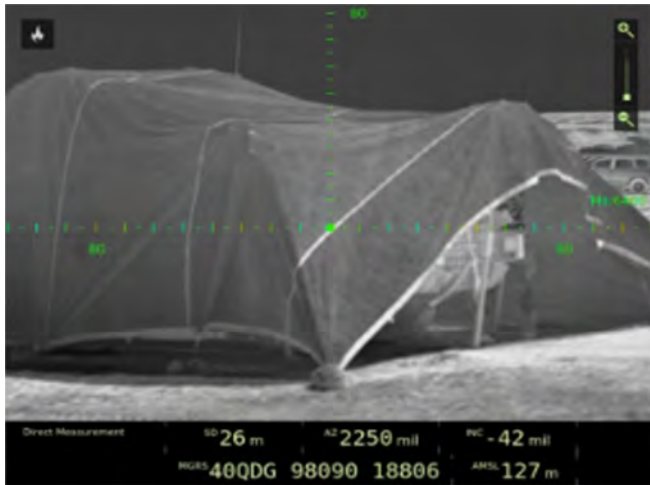

“This material can also be further enhanced with an additional semi-rigid lightweight material, which provides extra thermal protection.”

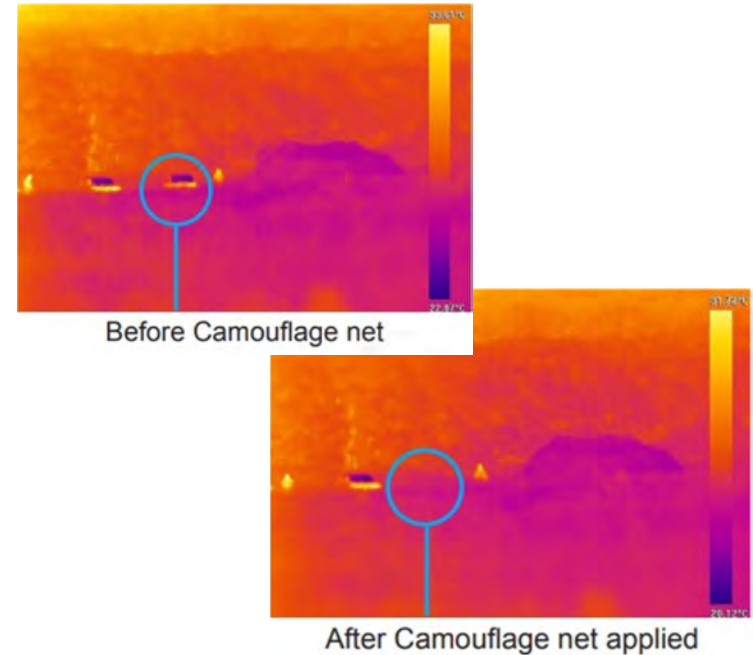

Mk8 Multi-spectral SMS protects the wearer in the visual, infrared (NIR & SWIR) and thermal spectrum's (MWIR & LWIR)

Used in the field by snipers/observation posts. Quiet, lightweight and easy to carry, it provides concealment from drones and advanced lenses.

- Designed to defeat Intensifier & Thermal optics
- Wired hood for ease of opening/closing
- Easy to move around in, quick to don and doff
- Breathable for comfort, low snag liner
- Anti Radar, water repellent finish
- Double-sided print (note only one side is 3D)

2 piece set - poncho and trousers

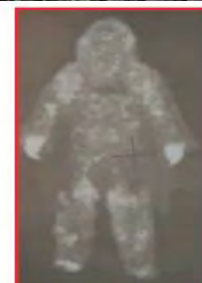

Hood Open

Hood Closed



Rock material.

- Similar spectrum protection to Sniper suit
- Double sided
- Light, 650g/m2
- Size 2mx3m packs to 30cm x 50cm



Mobile Multispectral (Vehicle) Camo (MMSC)

- Attaches to the vehicle.
- Easy and quick to change colours
- Safely allows relocation of Vehicles to redeploy
- Bespoke MSC panels
- Velcro-magnetic attachments
- Customised to allow access to all areas



NEW DESIGN



UK-MOD Crown-Copyright 2022

New MOD Military Vehicle on test using BCB camo livery

BCB's newly developed 3D/Multispectral Crinkle Camo(CC)

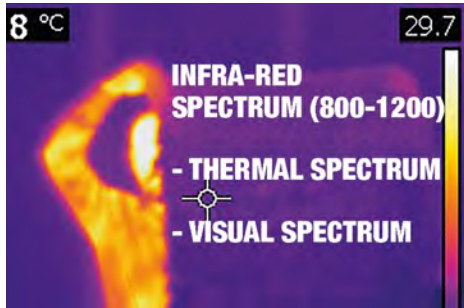

Unique crinkle texture blends better with nature

A new lightweight 3D material that can be used as camouflage netting and in signature management suits.

PROPERTIES:

- Operational temperature range : 45°C_+70°C. (EN 60068-2-2 / EN 60068-2-1)
- Fire resistance (ISO 6941)
- Resistance to Petroleum Oil: No deformation
- Washing Fastness: ≤ 4/5 ISO 105 C01
- Water Fastness: ≤ 4/5 ISO 105 E01
- Rubbing Fastness (dry) : ≤ 3 ISO 105-X 12
- Tear Resistance:
Warp: 24 N Weft: 23 N (DIN EN ISO 13937-2)
- Breaking Resistance:
Warp: ≥ 288 N Weft: ≥ 282 N (DIN EN ISO 13934-1)
- Air Permeability: 2398,5 mm/s (EN ISO 9237)



RAPIDLY DEPLOYED CAMO SCREEN

BCB's newly developed 3D/Multispectral Crinkle Camo(CC)

This concealment ensemble is made from a new, specialised lightweight, wearable material that helps the wearer blend into any natural environment whilst protecting them in the RADAR, INFRARED and THERMAL spectrums

FABRIC FEATURES:

- Random 3D 'Crinkle' pattern blends with nature.
- Non-s snag & breathable.
- Quiet and Lightweight.
- Fire Retardant & quick drying.
- OT range: -45°C to +70°C.
- WEIGHT: 2.07kg



Comfortable against the skin for long periods





Location Marker Balloon

- Designed by the military for the military.
- Can be quickly used to mark your Drop Zone position or if in need of rescue.
- Tethered high above any jungle on a 75 metre Kevlar cord
- Can be operated by one person within minutes
- Uses inert helium gas to inflate 136 litre Radar Reflective balloon
- Lightweight carbon fibre cylinder
- Large 1 meter balloon
- Day/night visible
- Radar Reflector
- Reusable





Fox Sleeping System

- Comfortable, compact and versatile
- A modular 3-in-1 jungle shelter system that can be combined or used independently
- Developed in conjunction with Special Forces



1. Forest Hammock

A generously sized, parachute grade, ripstop nylon hammock

3. Jungle Mosquito Net

A rugged, close weave polyester mosquito net. Clipped to fabric loops.



2. Lightweight Waterproof cover (Basha)

A lightweight robust shelter sheet forming fully tape-seamed and reinforced points.

- Compact and lightweight
- PU coated Ripstop Nylon
- NATO approved



CASEVAC SLIDE

RAPID
ARMOURED VEHICLE
EVACUATION

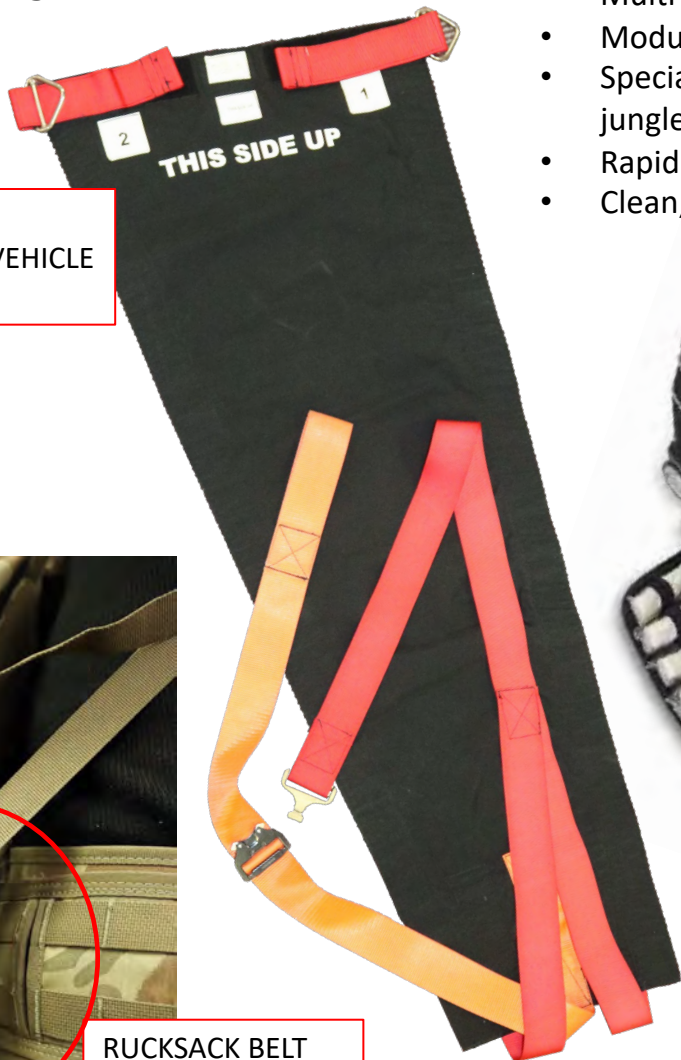

RUCKSACK BELT
QUICK-RELEASE
MECHANISMS



- Multi-functional and configurable
- Modular & integrated
- Special roles – airborne/maritime/ jungle to artic
- Rapid prototyping
- Clean, repair and renew in UK



MEDIC
TROLLEY
BAG

Honeycomb
internal layout
with removable
dividers.



Multi compartment
MEDIC THERAPY
TROLLEY with wheels

- Mesh Pocket
- 4 Detachable COLOUR-CODED Compartments, with handle.
- Three transparent pockets that allow the easy identification





FATS (Floating Armour Torso System)

A unique, versatile floating body armour incorporates a life jacket with both soft and hard armour. Low bulk and close fitting.



- Life jacket protected from bullet and fragmentation attack
- Automatically inflates within 3 seconds of water immersion
- Can be deactivated allowing diving up to 20m
- Reusable
- Waterproof armour
- Available in 2 variants - Low Profile (175 Newton) for air crew or vehicle crew or High Buoyancy (275 Newton) for Marine/Navy/Coastguard and Marine Police

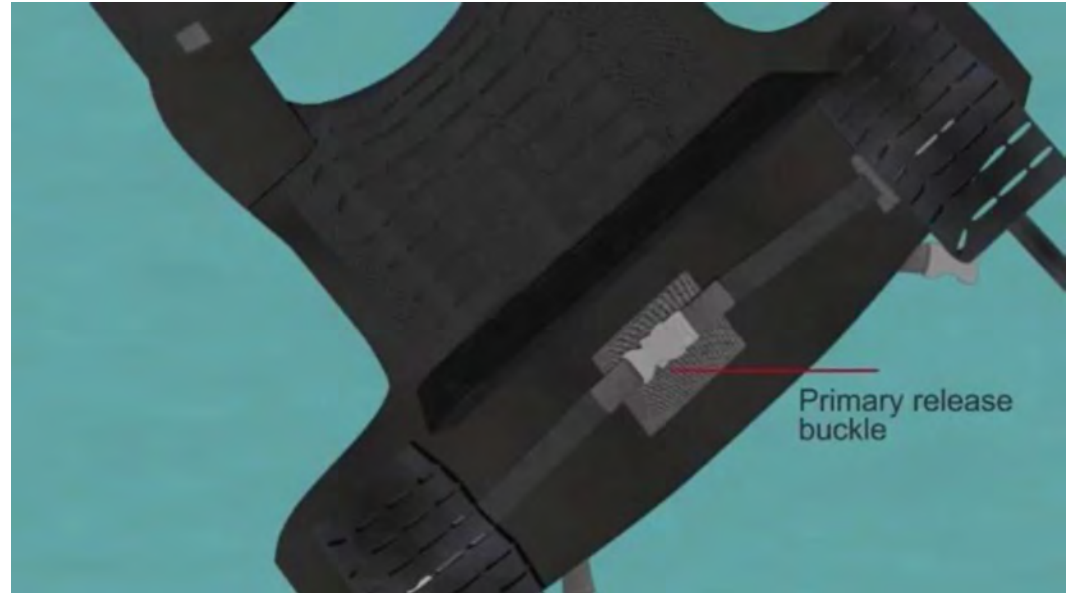



Blast Boxers

- The original patented pelvic protection
- Sculpted design - increased comfort
- Breathable fabric
- Laboratory and field tested
- Fire Retardant
- Anti microbial and anti odour
- No ballistic degradation following washing
- US Berry compliant – MADE IN THE UK and USA



Performance – Tested in accordance with MILSTD – 662F | V50 2gr RCC



Inner thigh
= 910 ft/s [227 m/s]



Upper front & back
= 910 ft/s [227 m/s]



Genital region
= 1020 ft/s [311 m/s]

Patented Design

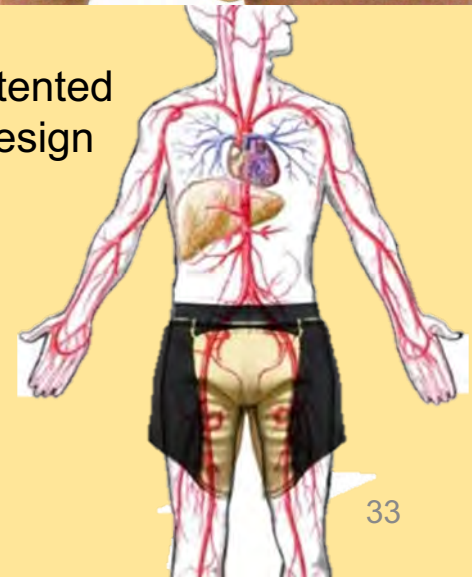

PMEK – Personal IED and Mine Extraction Kit

- Compact
- Reliable components.
- Easy to access
- MOLLE belt attachment.
- For every soldier to carry.



Can be opened with one hand.



SAFE Lane: Rapid Obstacle Clearing Kit

Light-weight
quick assembly kits
to clear Battlefield
Obstacles



- Pouch / Pocket to use in seconds
- Safe, quick to arm/dis-arm
- Effective and modular
- Lightweight
- Variable length and Explosive Weights

It Will Breach

- Paths, Doors, Walls, Fences, Gates
- Placed Obstacles / Hasty Obstacles
- Mines, Weapons Caches

The "Obstacle-Clearing kit" comes with everything required to clear small field expedient and deliberate obstacles, such as: concertina, mines, fencing, barbed wire and other battlefield emplacements.

It is lightweight and fits into a small manpackable belt pouch.

Simply add explosives, such as a detonation sheet, C4 or a slider charge.



Can be joined together
(with the gaffa tape
supplied)
to make a longer system.





Dragon Mk3

– A well-proven, versatile and mission-ready UAV Platform.

- FLIGHT TIME: up to 10 hours
- FLIGHT RANGE: 500 kilometres (2-way)
- PAYLOAD: up to 25 kilograms



Dragon-15
Wingspan:
3.8 Metre
Payload 15Kg.

Dragon-25
Wingspan:
4.5 Metre
Payload 25Kg.

Markets:

- Defence
- Security
- Mining
- Environmental and
- Science Industries





Investment in UAVE Ltd



Investment in UAVE Ltd.
a drone manufacturer in Wales.



Market Status

The drone/Unmanned Aerial Vehicle (UAV) market continues to expand rapidly. Due to the market potential, we have bought a 9% holding in UAVE Ltd a small loss-making drone designer and manufacturer.

We have the exclusive worldwide rights to sell their fully proven tried and tested Dragon 15 fixed wing UAV Platform. UAVE retain the rights for service sales. Other USPs for it include:

- **Long flight endurance**
- **Heavy payload-15 kilos (with a 25 kilo payload option)**
- **Can fly in a GPS deigned airspace.**
- **British design and manufacture.**

UAVE and BCB have also invested in developing a new fixed wing and VTOL (Vertical Take Off and Landing) hybrid product; the Buzzard. First flight expected February 2024.

The current sales leads confirms genuine interest, from Ukraine Defence Agency Procurement, UK MoD (last trials were in November '23) and NORCE (Air Force) Nigeria. Plus numerous other interested parties.



Prion Mk3 D15



UAVE Ltd



**STRONG,
VERIFIABLE
COMMERCIAL
INTEREST FROM
DEFENCE
MARKETS**

**FOUNDED
2013**

**BASED AT
WEST WALES
AIRPORT**



**RESPONSIBLE FOR
WORLDWIDE
SALES**

UAVE LTD

www.uave.co.uk

**GLOBAL
MILITARY DRONE MARKET is
projected to grow
at a CAGR of**

14.1%

In 2023-2030 Period

**UAVE RESPONSIBLE FOR
DRONE FLIGHT SERVICES
BUSINESS FOR A
REGULAR INCOME
STREAM**

**FY Predicted
Turnover '2024**

£2.4

Million

Example: UKRAINE only

Prion MK3 Dragon 15



MK3 Dragon 25



Buzzard Hybrid

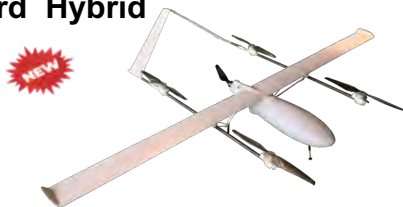

Selling £`000*					Selling £`000*
300	10	1	10	10	9,300
400	10				4,000
90	10				900
TOTAL					14,200

*Airframe price only. Payloads will be extra.



Expanding UAV Range

Expanding UAV range with Drone Evolution (DE), drone manufacturer, near BCB int., Cardiff

Market Status

BCB currently supply to Ukrainian market 3 types of British made quadcopters, included lightweight and low cost FPV drones.

Drone Evolution UAVs is an ideal platform for collaboration for various missions included defence, surveillance and humanitarian demining etc.

BCB have the exclusive rights to sell their fully proven technologies in Ukraine & Iraq.

Within range are:

- Runner**
- an autonomously programmed, low cost UAS, designed to carry small payloads.
- Sentinel**
- Tethered Drone System can stay in the air for hours at a time.
- Scimitar**
- small but mighty weather resistant drone with very competitive price.

DE is one of the leading suppliers of drone-based services within UK and a major player in the tethered drone and specialist powered markets with a global capability to deliver tethered drones.

R&D department of DE actively utilizing feedback from end users in Ukraine with active support of BCB. So, DE produce best innovative products that suits growing market demands. DE also developing extra features for existing standard packages.





The current sales leads confirms genuine interest, from Ukraine Defence Agency Procurement, Administration of the state Border Guards Services, JSC Meridian in N.P Korolov, Defence Intelligence, collaboration opportunities within defence companies and from Iraq.



Representatives of BCB int & Drone Evolution during humanitarian demining forum Security 2.0 (Kyiv, Oct, 2023) shown Runner & Scimitar drones



By powering the drone via a tether, attached to a ground station, the drone can stay in the air for extended periods of time.

Customer name	Product name	Price per item, EUR	Selling price per item, EUR	Quantity	Contract amount, EUR	Value, EUR	Time of contract	Notes and comments
Administration of the State Border Guard Service www.dpsu.gov.ua/en 	MK3-Dragon 15	200,000 €	350,000 €	10	3,500,000 €	1,500,000 €	2nd quarter 24	Much will come from the British partners of the Ukrainian border guards. They must contact us somehow. Apparently after the New Year. The positive thing is that Ukrainian colleagues promised to write the technical characteristics of the UAV that they need. Also, Ukrainian colleagues asked to test some of our products. Ref.letters dated December 20 and 22.
	MK3-Dragon 25	300,000 €	450,000 €	10	4,500,000 €	1,500,000 €	3rd quarter 24	
	Buzzard VTOL	60,000 €	100,000 €	10	1,000,000 €	400,000 €	3rd quarter 24	
Ukrainian state-owned foreign trade enterprise. SpetsTechnoExport (STE) www.spetstechnoexport.com 	MK3-Dragon 15	200,000 €	350,000 €	1	350,000 €	150,000 €	2nd quarter 24	We are awaiting an official letter from Spetstechnoexport about their readiness to organize testing of the MK3 Dragon 15. They can purchase goods in the interests of the Main Intelligence Directorate for their budget.
Defence Intelligence of Ukraine www.gur.gov.ua/en.html	MK3-Dragon 15	200,000 €	350,000 €	10	3,500,000 €	1,500,000 €	3rd quarter 24	During the tests of Dragon 15, which will be organized by Spetstechnoexport, representatives of the Main Intelligence Directorate will be the main experts and customers. Based on the test results, it is planned to place an order for a UAV.
Ukrainian-Taiwan Initiative Organization UTIO. Eduard Lanovik 	MK3-Dragon 15	300,000 €	450,000 €	11	4,950,000 €	1,650,000 €	3rd quarter 24	There is an opportunity to develop this direction from Edinburgh, since persons interested in the success of this transaction are here and can influence a number of processes in Ukraine
	MK3-Dragon 25	200,000 €	350,000 €	15	5,250,000 €	2,250,000 €	4th quarter 24	
State Enterprise Specialized Foreign Trade Firm "Progress" www.progress.gov.ua/en/ 	MK3-Dragon 15	200,000 €	350,000 €	10	3,500,000 €	1,500,000 €	2nd quarter 24	There is hope for more fruitful interaction with this organization. In 2024 we will write them official proposals.
					Contract Sum	Value Sum		
					26,550,000 €	10,450,000 €		

MK3 Dragon-15 with skids taking off from mobile launcher





Buzzard hybrid Fixed wing/VTOL

Wing design maximizes stability and heavy wing loading for the small VTOL platform = LOW stall speeds, high max EFFICIENCY, a large payload CAPACITY and HOT SWAP features, detachable equipment compartment and the LONG ENDURANCE gasoline engine power system.

This equates to less energy expended and more time in the air.

- Ideal combination of high energy density gasoline and high efficiency electric motor
- Complete composite construction using carbon fiber and Kevlar on a rigid honeycomb core structure
- New fuselage design concept that conceals all avionics cables
- Robust structure engineered to industrial quality
- Redundant power system for flight controller to maximize safety
- Compatible with PC-based, full-featured, Prion Mk 3 autopilot system
- Built in 6 to 8L fuel tank.
- Easy to assemble in the field, no need for expert skill. Can be assembled in 15 minutes.
- VTOL to suit virtually most surveillance missions

Payload = 3 to 109 kg
ENDURANCE = 3 hrs (Motor) to 5 hours (Endurance)
SPEED = 100 to 120 km/hour
ALTITUDE = 13,120 ft (maximum)
MTOW = 40 kg

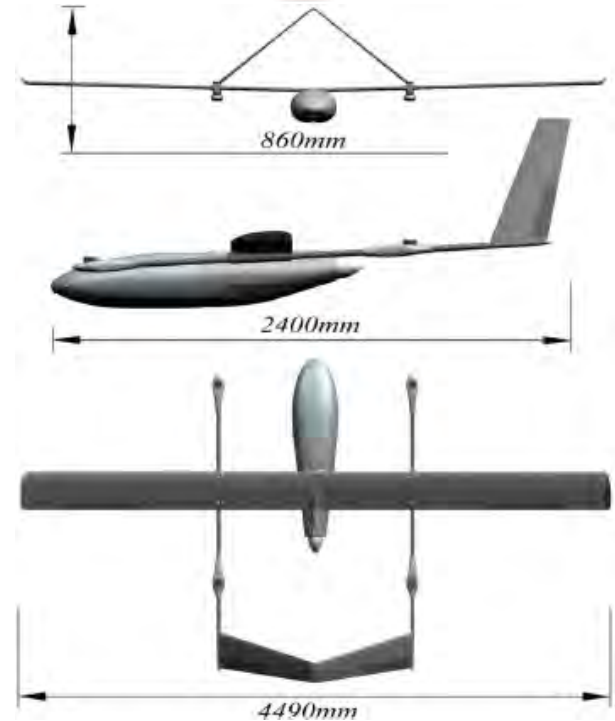



50mm wide quick release double secured straps.



Removable head pad.

Micro-stretcher
– for rapid deployment in war zones

Adaptable rescue methods

Suitable for :
4-person horizontal lift
6-person horizontal lift with strap
Vertical winch by helicopter/
mechanical means with hoisting strap assembly* (extra)



6 mesh fabric sections with fast lock hollow carbon fiber poles which slide in/out



- Fast assembly below 20 seconds.
- Effective protection & safety: Removable head support & strap.
- 4 restraining straps, groin /over body straps & spinal support for ease of securing the casualty.
- Easy assembly: No training necessary.
- Folds into 6 sections, so easy to stow
- Strong and durable rigid stretcher: Strain tested to transport a load of 311 kilo (equivalent to 47 stone).
- Easy to clean, mesh fabric & frame.
- Back-packable for hands-free carrying.



Survival & Medical Kits

- Innovative and intuitive survival solutions for over 50 years
- For fast jets, rotary wing and transport planes, tanks and armoured vehicles
- Individual or group survival packs
- Supplied to Special Forces, Air Forces and Land Forces
- We have helped save many thousands of lives over the years





Medical Solutions

- Innovative and intuitive medical solutions for over 50 years
- Individual or group packs
- For Air Forces, Land Forces, Maritime, Polar
- Jets, rotary wing & transport planes, armoured vehicles,
- Basic to Platoon Packs
- Vacuum packing
- Medicine Licence



IFAK

- Tough, compact
- Internal pockets
- MOLLE-compatible
- Quick, easy access
- Easy pull zip handles



SPECIALIST FIRST AID PACKS Sets & compact versions

specialist DRESSINGS



Batch : INT22138 D.O.M. 03/2019
 STORE BELOW 25°
 www.bcb.in.com

Functional, rugged furniture currently in service with the UK MoD

- NATO codified
- Robust
- Lightweight
- Space efficient

Rugged Camp Cot



Disassembly of Camp Cot

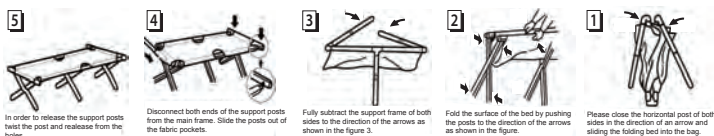

Field Desk:
Transportable
Easily deployed
Privacy Screen
Secure storage

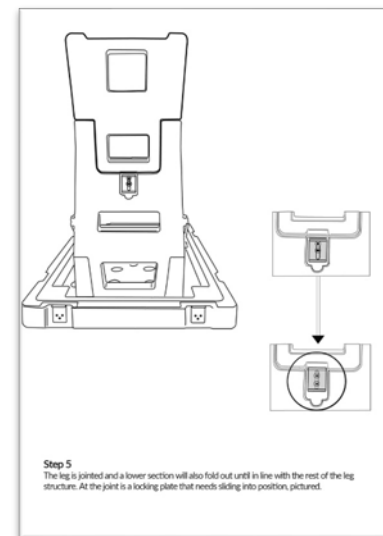
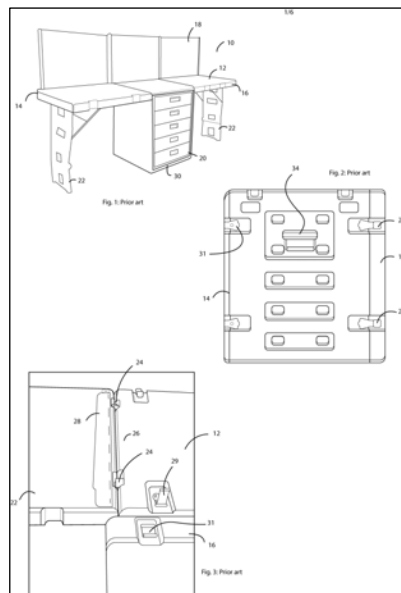



Field Sleeping Systems



Self inflating Sleeping Mat



Modular Sleeping Systems
LIGHTWEIGHT & MEDIUM
WEIGHT



SOFT INNER LINING
FOR COMFORT

HEAD PROTECTED
WITH ZIPPERED
INSECT NETTING

WATERPROOF
OUTER LINING ON
UNDERSIDE



4 Seasons
Sleeping Bag



~11.2 °C

27.8

FLIR

8.1



Mattress

Mosquito
Net on a
camp cot





Boat Stopping System (BSS)

- **Non-Lethal**
 - **100% effective; it doesn't need to snag or entangle the propeller**
 - **Simple to use; just uses compressed air**
 - **Provides a layered defence**
 - **Scalable for large & small boats**
 - **Does not damage or sink the target boat**
 - **Can also be used to deploy survival equipment**
 - **Extensively tested and in service**
 - **Significant and reliable stopping power**
- More can be seen at: <https://www.youtube.com/watch?v=zTCqceRSeX4>
 - Repeat orders from the UK navy.
 - The US Navy and maritime Army have conducted extensive trials.
 - US Navy purchased for extended trials at the US Naval Surface Warfare Centre.
 - Other forces are keen to trial including the UAE navy, Singapore, India, Kuwait, Indonesia, Japan, Malaysia, Spain, Malta, Saudi, Korea, France, Italy and Denmark.
 - World patents granted





BCB developed the first ever survival and medical equipment for life rafts and lifeboats. High cost of entry as it is highly regulated and requires extensive testing and thus has few competitors. This market, though only growing at 5.3% (2019 Plimsoll) does provide a regular, reliable demand for our life saving marine products.



Medical Equipment –

BCB designed the first medical equipment for use in life rafts and lifeboats over 60 years ago. The Company produces its products to international SOLAS or EU standards.



Survival Kits –

BCB is the developer of much of the current survival equipment that is now standard in life rafts and lifeboats. The kits are SOLAS and IMO approved.



Marine Polar Range



Specialist Marine and extreme cold weather survival equipment for commercial.
Personal kits • larger group kits.



Both kits comply with the Polar Code (IMO Resolution MSC.385(94)), PART I-B paragraph 9.2



Polar Kits - A new regulation called "The Polar Code" which required all international shipping to carry new extreme cold weather survival packs. BCB was instrumental in helping design the products which have now been extensively adopted by most vessels going into the Polar regions. Due to climate warming the North West passage is now more accessible than ever.



BCB have developed and manufactured polar survival kits in accordance with the new IMO Polar Code. Waterproof durable, robust, float when packed in their bespoke waterproof kit bags. They are specially designed to aid survival in the polar regions. Tested in the extreme of the Polar regions.



Marine offshore health, safety and personal protection equipment is carried for support vessels or each turbine.

Running stock will be maintained at the onshore OMS logistics facilities.

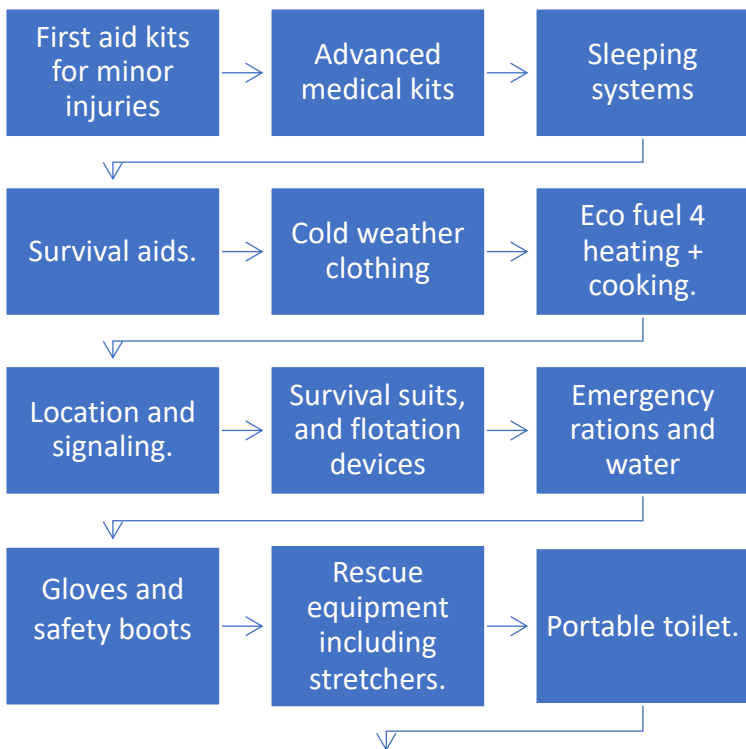

To permit overnight occupation in the turbine in the event of poor weather or support vessel issues.



Growing offshore wind market.



Outdoor Market

Camping, Bushcraft, and fishing products

User friendly B2C eCommerce site, “trade only” section, and Rapid dispatch



Available in over 800 outlets in UK

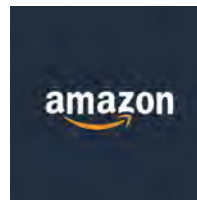

FireDragon Fuel for Ukraine project. (FFU)

FIREDRAGON
High Performance
Eco fuel



BCB, Vinnytsia National Technical University and Golden Box have an opportunity to distribute our clean cooking fuel, FireDragon to Ukraine.

AIM: SOLVE the Ukrainian energy crisis

FIREDRAGON

ATTRIBUTES:



SUSTAINABLE - Made from waste vegetation.



BURNS CLEAN – HUGE REDUCTION

in greenhouse gases (100% less methane than charcoal/firewood).



BURNS SAFELY INDOORS

Perfect for users in apartment blocks in blackout.

COMPATABLE WITH MOST STOVES

perfect for soldiers and the internally displaced.



VERSATILE

Easily lit in all weathers, even when fuel is wet.

STATUS:

- PROJECT FUNDS APPROVED
- Project worth £1,286,999.
- PURPOSE: Ethanol (FireDragon) production
- LONG TERM strategy for FireDragon PRODUCTION & DISTRIBUTION.



BENEFITS:

- **IMPROVE GREEN ENERGY ACCESS**, localising production will bring to market an affordable clean cooking fuel.
- **CREATE LICENSED EMPLOYMENT**, creating an income for desperate families in the war-torn state.

RESEARCH + LOCAL PRODUCTION

=

- Affordable
- Available
- Low cost



TARGET MARKETS:

- Ukrainian households.
- Internally Displaced
- Ukrainian Troops

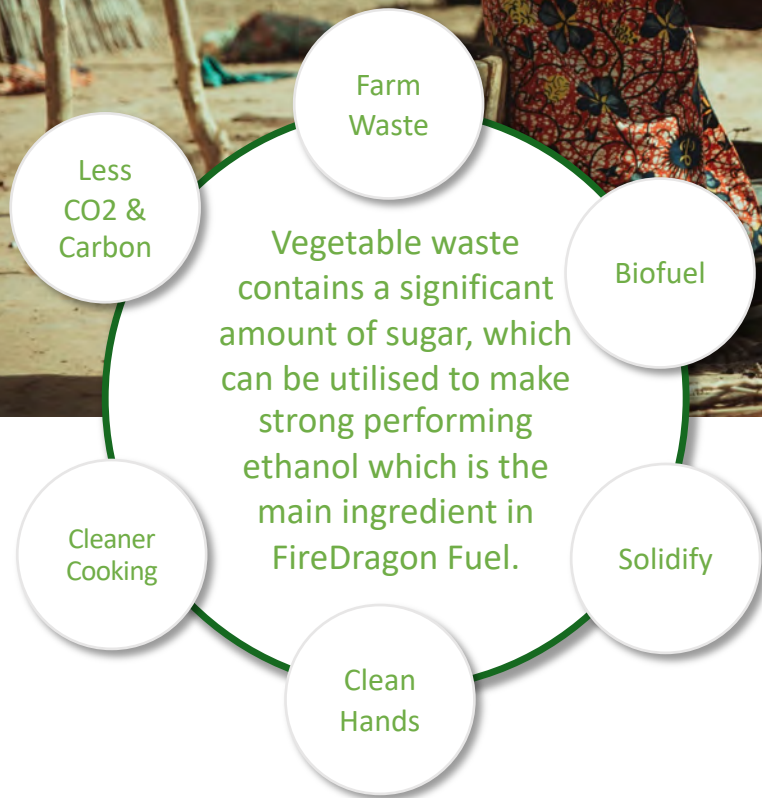

The Sustainable and Affordable Fuel for Energy (SAFE) project.

Solution: to clean cooking for over 4 million people worldwide

FireDragon boasts the following attributes:



Sustainably Produced from waste vegetation.



Burns cleanly, it emits considerably less greenhouse gases than wood or charcoal (**100% less methane compared with charcoal/firewood**).



Is Compatible with popular charcoal and firewood stoves, removing installation costs.

The SAFE project is **sourcing investment** to establish in country liquified and solidified ethanol production.

Localised Production will bring countries the following benefits:

- **Improve green energy access**, localising production will bring to market an affordable clean cooking fuel.
- **Create licensed employment**, creating an alternative to illegal and dangerous charcoal economies.
- **Economize food waste**, liquified ethanol is made from waste vegetation, this will economize a wasted agricultural resource and create an additional income for farmers.





Summary

Expertise in light engineering, medical, camouflaged products and chemical formulations.

Balanced and experienced management team with good financial control and proven production, quality control and distribution structure.

Approx. 550 innovative items. NATO approved. BCB's own design, unique, and IP protected.

Historically, BCB's primary customers have been the UK MoD and manufacturers of life rafts and lifeboats.

Exports 40% to military, security & marine services.

Well established network of sales distributors and direct government long term contracts.

Excellent name and reputation in the 3 diverse, complementary and growing markets.

For over six decades BCB has been at the forefront for some world leading innovations to help save lives and are well known to its customers for the quality of its products.



Three Soldier Technology awards for innovation



Two Queen's Awards for Export Achievement

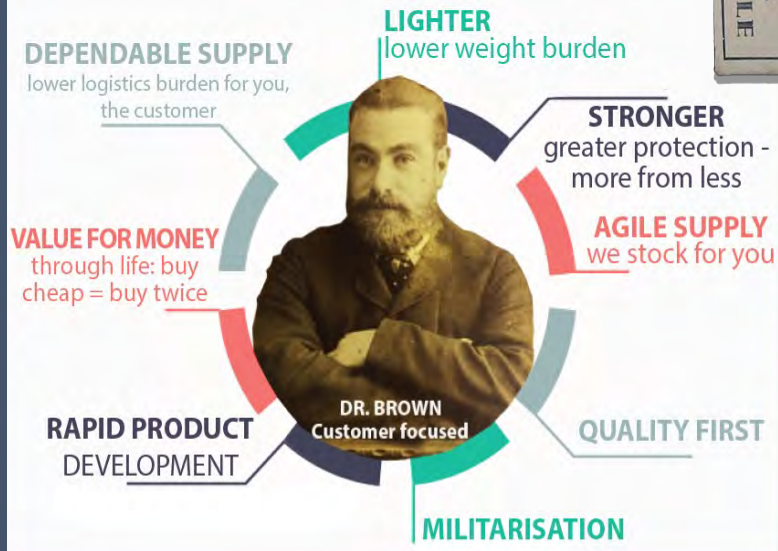



Conclusion

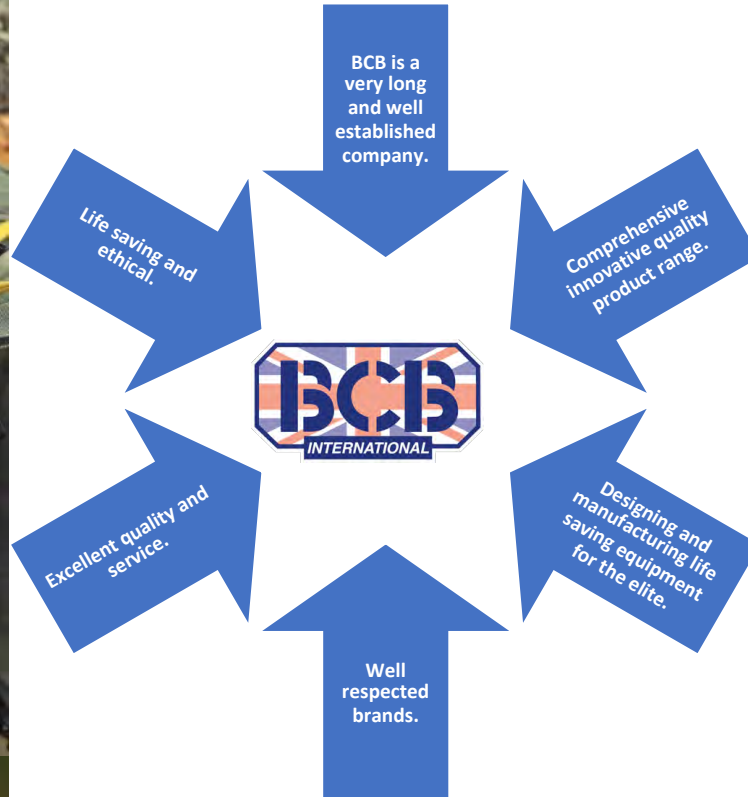

- Considerable investment into R&D and capital equipment.
- Having 3 diverse markets is a great strength, especially in volatile global markets
- Defence and Marine markets provide good long term contracts which underpin revenue streams.
- Product rich, IP protected company.



FIRE DRAGON



“Saving & Protecting Lives in Hostile Environments Through Rapid Innovation”



Uniforms

Outer, Inner and Layered clothing

- Compact
- Performance
- High insulation to weight/loft ratio
- Reflective inner scrim



- Multispectral camo
- Fire retardant
- High performance & lightweight
- From cold, wet weather to hot & dry
- Function, weight, then comfort
- Base longer to outer wear, the bits in-between and on the ends.



INCORPORATES
ELBOW AND KNEE PADS

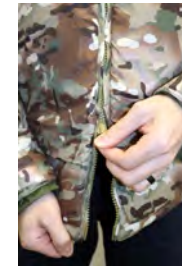
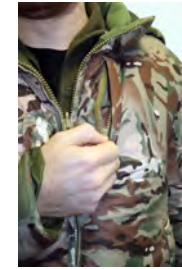



Webbing and Heavy Textiles

- Can offer local refurbishment/repair to improve through life cost and sustainability
 - Reshoring to improve supply chain security

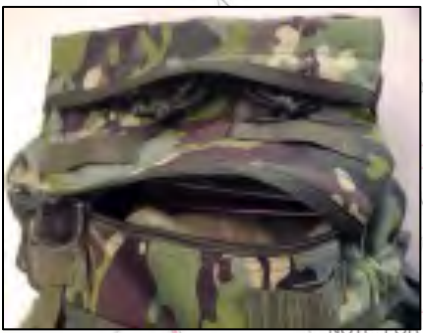
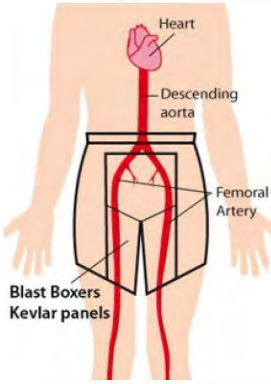

A POG saves lives by protecting the vital femoral arteries and groin area.

QUICK RELEASE COMBAT ARMOUR CARRIER

Modular 360° carrier

Multi pouches capacity-

- 2 Large Front & Back Plates
- Plus 2 Side Plates
- Front and Back Soft Armour inserts



WITH BELT

- Flexible Spine – rises/lowers
- 4-Way Cutaway System
- Rapid Release - < 5 SECS
- Reconnect <30 SECS
- Weight 1.68 kg



FRONT



OBLIQUE



REAR
PLUS EXTREMITY ARMOUR



WITH BELT & HARNESS